



Going Wild!

Teaching about Wild Products from
BC's Coastal Rainforests

A Guidebook for Educators for Grades 4-7



A collaborative project of the Coastal First Nations
Great Bear Initiative, Sierra Club BC, and the Centre
for Non-Timber Resources at Royal Roads University



Initiative



SIERRA
CLUB
BC



ROYAL ROADS
UNIVERSITY

Centre for
Non-Timber Resources

Sierra Club BC and Coastal First Nations Great Bear Initiative © 2015

Permission is granted for the duplication of this guidebook for educational and non-profit uses only. For all other duplications or uses please contact **Sierra Club BC** or **Coastal First Nations Great Bear Initiative**.

www.sierraclub.bc.ca

www.coastalfirstnations.ca

This guidebook is printed on:

Cover - 10% post-consumer paper

Inside stock - 100% post-consumer waster paper



Guidebook design and layout by Pharis Romero with Barn Swallow Arts.

ISBN 978-0-9783721-2-5

"copyright 2009, reprint 2015"





Table Of Contents

Acknowledgements	1
Welcome.	3
Introduction to this Guidebook	4
Learning Outcomes	4
Traditional Knowledge and Teaching	5
How do I use this guidebook?	6
Who is this guidebook for?	6
Wild Products: An Introduction	7
What are Wild Products?	7
How are Wild Products Used?	7
Wild Edibles	8
Medicinal Uses	8
Floral Greenery	9
Crafts and Art.	9
Species Backgrounders	10
What are species backgrounders?	10
How do I use the backgrounders?	10
Where can I learn more?	10
<i>Red Huckleberry.</i>	11
<i>Mushrooms.</i>	13
<i>Labrador Tea</i>	15
<i>Devil's Club.</i>	16
<i>Pacific Yew.</i>	18
<i>Salal</i>	20
<i>Sword Fern.</i>	22
<i>Cedar</i>	23
Activities.	27
Activity Structure	27
Learning Themes.	28
Activities-at-a-Glance	28
Creating a Portfolio	30
Taking your Classroom Outside.	30
Working in Small Groups	30

Getting to Know Wild Species	31
<i>Activity 1 - Get to Know a Plant</i>	31
<i>Activity 2 - Learn about Leaf Patterns.</i>	33
<i>Activity 3 - Make a Plant Map.</i>	37
<i>Activity 4 - Thanks for Plants (Summary Activity)</i>	41
Wild Edibles	42
<i>Activity 5 - How to Sustain Ecosystems</i>	42
<i>Activity 6 - The Forest Food Web Game</i>	47
<i>Activity 7 - Making a Seasonal Harvest Calendar.</i>	52
<i>Activity 8 - Gathering Berries for Jam.</i>	53
<i>Activity 9 - The Business of Mushrooms</i>	56
Medicinal Uses	59
<i>Activity 10 - Learning about Devil's Club.</i>	59
<i>Activity 11 - Making Tea.</i>	62
Floral Greenery	65
<i>Activity 12 - Making Wreaths.</i>	65
Crafts and Art.	68
<i>Activity 13 - Cedar Weaving.</i>	68
<i>Activity 14 - Cedar Stories.</i>	72
Wrap-Up.	78
<i>Activity 15 - Wild Products Fair (Conclusion Activity).</i>	78
Glossary	81
References	83
Resources	85
Books	85
Websites	86
Appendix A: Specific Prescribed Learning Outcomes	87
Arts Prescribed Learning Outcomes	94
Appendix B: Field Trip Checklist	95
Appendix C: Working in a Small Group	97



Acknowledgements

Many people have contributed their time, energy and expertise to developing, revising and reviewing this guidebook. Thanks go to community members and the board of directors of the Coastal First Nations Great Bear Initiative for encouraging the development of this guidebook. Thanks to the NTFP Working Group for making this project a priority. A special thanks to the Advisory Committee who helped to conceptualize this guidebook and oversaw its development: Jessie Housty, Lillian Howard, Maryann Enevoldsen, Johanna Gordon-Walker, Leslie Bellis, Lana Wilhelm, and Bess Brown. Thanks to the project team: Kerri Lanaway, Johanna Helbig, Claire Hutton and Tim Brigham. Thanks to the Sierra Club Education Team who helped to pilot the project: Rachael Black and Erica Spearman. Finally, a special thanks to the people who developed the content: Nick Stanger, Robin June Hood, Nadine Lefort and Susan Gage.

Sierra Club BC, the Centre for Non-Timber Resources and the Coastal First Nations Great Bear Initiative would like to acknowledge the generous support of the following funders:

- The Wilburforce Foundation
- The William and Flora Hewlett Foundation
- The David and Lucile Packard Foundation
- The Nature Conservancy
- Tides Canada Foundation

Additional support for this guidebook was generously provided by:

- The Rainforest Solutions Project, a joint initiative of ForestEthics, Greenpeace and Sierra Club of BC
- TD Canada Trust Friends of the Environment Foundation



Welcome



Tsuu aay 'kiing jah

We will look into the heart of cedar and walk in the majesty of the great magician.

Guujaaw

Former President

Coastal First Nations Great Bear Initiative



A Letter of Welcome

A few years ago, we held community workshops to explore Non-Timber Forest Products and income generation from harvesting and crafting wild products. We heard a clear call for the need to re-connect our children and youth with the plants, forests, medicines and traditional practices that surround us in the temperate rainforest in which we live.

As we move forward with ecosystem-based management on the Central and North Coast and Haida Gwaii through our land use planning processes, we are also seeking ways to protect and wisely use our forests to enhance our well-being. Being out on the land, gathering mushrooms and berries for food and cedar bark for weaving, transmits traditional knowledge through the ages, from elder to child, from generation to generation. Our lands, waters and cultures make us strong and define who we are, as First Nations and individuals. Out on the land, we are the eyes and ears of our communities, monitoring the health of the ecosystems around us while managing and stewarding our environment.

It is my hope that teachers will find this guidebook and its activities useful for imparting a sense of curiosity about the wild plants in our forests, and equally as important, the realization that people are making incomes from wild products, leading to a better quality of life, and looking after the environment at the same time.

Art Sterritt
Executive Director
Coastal First Nations

Initiative



Introduction To This Guidebook

What type of plants did our ancestors collect and use from our coastal forests? How do people use these plants now? Why are they important to you and your family? How can we learn to recognize them and continue to use them in a sustainable way to strengthen our communities?

This guidebook will help you and your students explore these questions. It provides background material on some special plants and mushrooms from the rainforests of BC's Central and North Coast and Haida Gwaii that are important for many reasons. The activities in this guidebook focus on these species, how they are used and why they are important. The activities are designed for grades 4 to 7, but also include extension activities for other grades.

Going Wild! Teaching about Wild Products from BC's Coastal Rainforests has been developed specifically for First Nations on the Central and North Coast and Haida Gwaii, but it can be used as a resource for other coastal communities and in other locations in BC where these plants are found. We hope that this guidebook will be a useful tool in helping your students find a closer connection with their environment, and with plants that have been, and continue to be, important to their communities.

Learning Outcomes

Going Wild! Teaching about Wild Products from BC's Coastal Rainforests addresses the need for increased environmental awareness and appreciation of wild products (also known as non-timber forest products), and it encourages all of us to recognize that forests are far more than just timber-producing ecosystems.

The activities in this guidebook fulfill the following **Learning Outcomes**:



- to learn about wild products, and to learn about and describe local plant species;
- to explore relationships between humans, plants and ecosystems;
- to learn concepts of sustainability through studying the use of wild products;
- to better understand and respect traditional practices of local First Nations related to the use of wild products;
- to learn about some potential sustainable options for community economic development based on the use of wild products.

Each activity covers British Columbia Prescribed Learning Outcomes for one or more of the following: Science, Mathematics, Visual Arts, English Language Arts, Social Studies, Physical Education, and Health and Career Education. Specific learning outcomes for each activity can be found in **Appendix A**.

Traditional Knowledge and Teaching

Going Wild! Teaching about Wild Products from BC's Coastal Rainforests draws on both modern and traditional knowledge from British Columbia's Central and North Coast and Haida Gwaii. Here's one definition of traditional knowledge:

... the knowledge, practice, and belief concerning the relationships between living beings to one another and to their environment, based on generations of intimate contact with the land. It includes an ethic of interconnectedness and respect, and is therefore woven into and inseparable from a culture. Traditional knowledge is generally transmitted orally, through songs, stories, legends, and practices, and it is always changing, as does our environment. Traditional knowledge is generally considered collective to a community or nation, not to a particular individual.

(Berkes, 1999)



When working with traditional knowledge, it is important to consider the generations of understanding, and the spiritual significance that underlies this knowledge. While some traditional knowledge is general and is openly shared, some information is sensitive and can only be shared when permission is given.

Throughout this guidebook we encourage teachers to involve local knowledge holders such as Elders and other important community resource people in the students' learning about the uses and importance of non-timber forest products. Are you aware of who you can ask from the community to work with your students on different topics covered in this Guidebook (e.g. Elders who could share stories about important plants, artists who work with cedar, community members who harvest wild plants, etc.)? If you need help finding resource people to work with your class try contacting the Education Coordinator or Education Department at the Band office, the Cultural Liaison people who work in the school, the School Principal, or other teachers.

How Do I Use This Guidebook?

This guidebook consists of two major sections:

- **Wild Products: An Introduction** – This section consists of an introduction to help you and your students understand what wild products are, and how they are used. The Species Backgrounders are a series of 8 student handouts that profile species commonly used by First Nations of BC's Central and North Coast and Haida Gwaii, highlighting some of the important artistic, cultural, nutritional, medicinal and economic uses of these species.
- **Activities** – The 15 activities use interactive, learner-centred methodology to help your students interact with wild products. They can be taught in any order; each activity stands alone, but can be effectively linked with others. Use the suggested extension activities to challenge advanced students, to teach to higher grades, or to take your whole class to another level of analysis or creativity.



Some of this guidebook may be photocopied. Look for the Student Handouts after each Activity.

Who Is This Guidebook For?

This guidebook is for educators, including classroom teachers, non-formal educators, park interpreters, camp counsellors, after school program facilitators, parents, grandparents, youth, and anyone else who is interested. We hope that this resource will become a community resource, drawing traditional knowledge holders into the classroom, and students out of the classroom and into the forest.

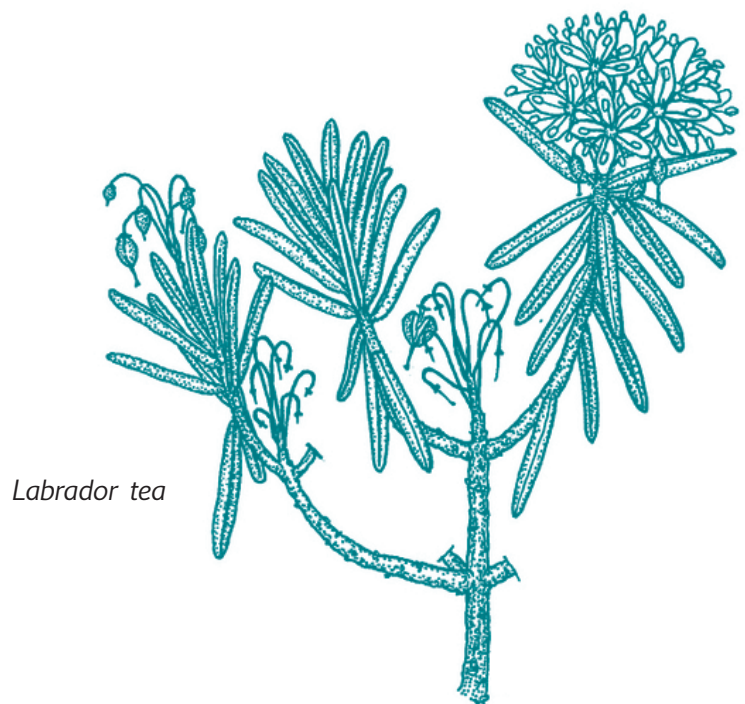

Wild Products: An Introduction

What Are Wild Products?

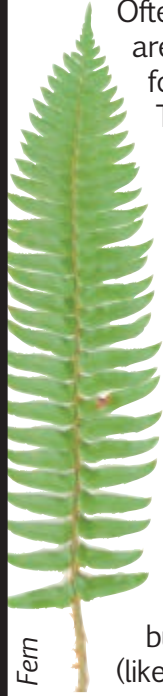

Sword Fern

Often when we think of forest products, we think of trees for timber. But there are many plants and mushrooms that grow in the forest that humans have used for thousands of years. What we call “wild products” are also called “Non-Timber Forest Products” or NTFPs for short. NTFPs are all of the plants and mushrooms in the forest other than timber, pulpwood, shakes, or other wood products that have cultural, spiritual, recreational, commercial and subsistence uses. Some examples of NTFPs are: berries, wild mushrooms, floral greenery, plants for medicine, and craft and art materials.

Wild products are important for many reasons – they feed us, provide us with medicine, support our culture, provide us with material to make things with. More recently the harvesting and selling some of these plants and mushrooms has become an important activity in many parts of BC including on the North Coast, Central Coast and Haida Gwaii. Thousands of people throughout the province harvest wild products on a part-time basis, selling what they pick to other businesses or sometimes making their own products (like berry jam or Christmas wreathes) to sell to people in their community. For some communities, the harvesting and selling of these products provides an opportunity for lots of different people in the community to earn an income from the forest without having to cut down the trees.



Chanterelle

For more information on wild products go to the website for the **Centre for Non-Timber Resources at Royal Roads University**: cntr.royalroads.ca/community_toolkit.

How Are Wild Products Used?

The money made from wild forest products in BC adds up to hundreds of millions of dollars annually – and in Canada as a whole it may be over a billion dollars per year (CFS, 2007). Many of these wild products are important for other reasons too. Dr. Nancy Turner, a celebrated ethno-botanist (a scientist who studies how people use plants) at the University of Victoria, points out that these plants have been used for a long time:

For British Columbia First Peoples, many of the forest species identified as potential products in a new economy have high cultural values and have been used for food, materials, and medicines since time immemorial.

(Turner, 2001, p.2)



Woven cedar bark hat

In this guidebook, we focus on the following areas: **Wild Edibles, Medicinal Plants, Floral Greenery, and Crafts and Art.**

Wild Edibles

First Nations people on the coast have been harvesting food from the forest (edible plants) for many thousands of years. Certain ferns, berries, roots, and leaves of many plants and trees have been eaten for a long time, and continue to be eaten today by many different people. Wild mushrooms have become an increasingly important wild edible product that is harvested in coastal BC.

See the **Species Backgrounders** on **red huckleberries** and **mushrooms** for more information on wild edibles.



Red huckleberry



Chanterelle mushroom

Medicinal Plants

Many plants from the forest are used as medicines. They are prepared in many ways including as balms, tonics, salves, lozenges and teas. Cottonwood buds were used as a balm for burns and scratches, and Douglas fir pitch was also used to help heal wounds. Salal was used as a tea, and as a balm for insect bites. Labrador tea was used as a tonic and a tea by many First Nations people. Devil's club is used by many First Nations for its healing medicine. Pacific yew has been more recently used as a source of paclitaxel, a drug that has proven to be effective against a variety of cancers.

See the **Species Backgrounders** on **Labrador tea, Pacific yew,** and **devil's club** for more information on plants with medicinal uses.



Pacific yew

A Note On Medicines

Because medicine is often sacred, it is important to check with local Elders in your community to ask if it's okay to talk about certain traditional medicines.



Labrador tea



Devil's club

Floral Greenery

Floral greenery is an important part of the wild products industry in British Columbia. Have you ever looked at a bunch of flowers and noticed that flowers are only part of the bouquet? Salal is used extensively in floral arrangements; other greenery products such as conifer boughs (for example, cedar and pine), boxwood, evergreen huckleberry, sword fern and other species are harvested and sold in much smaller quantities. Sales of all these products put together total about \$50-60 million per year (Forest Practices Board, 2004).

For more information on floral greenery products, see the **Species Backgrounders** on **salal** and **sword fern**.

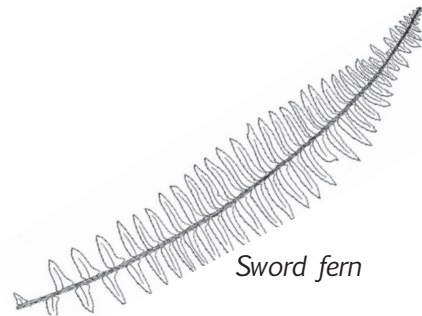

Sword fern



Salal

Crafts and Art

Crafts and Art refers to all the things made from forest plants that are built, woven, painted or carved. Crafts and art are an important part of First Peoples' spiritual and cultural relationships with the forest.

Wild products made with wood use smaller portions of wood than is needed for construction purposes. Wood for wild products is often salvaged from wood left over from logging, or from dead trees that have fallen in the forest.

Cedar and **Pacific yew** are both very important woods used for crafts and arts in coastal cultures. To learn more about these two species, go to the **Species Backgrounders**.



Cedar



Pacific yew



Species Backgrounders

What Are Species Backgrounders?

Wild Edibles

Red Huckleberry (Backgrounder 1)
Mushrooms (Backgrounder 2)

Medicinal Uses

Labrador Tea (Backgrounder 3)
Devil's Club (Backgrounder 4)
Pacific Yew (Backgrounder 5)

Floral Greenery

Salal (Backgrounder 6)
Swordfern (Backgrounder 7)

Crafts and Art

Cedar (Backgrounder 8)

The **Species Backgrounders** are eight student handouts that profile different forest plants and mushrooms. We have chosen these eight species because:

- they are relatively abundant and easily identified;
- many of them have a history of First Nations, as well as non-First Nation, uses;
- they represent different uses including cultural and commercial uses.

How Do I Use The Backgrounders?

To prepare to use this guidebook, we hope that you will take some time to walk around the forest near your school, identifying the plants profiled in the **Species Backgrounders**.

These eight handouts contain information that supports many of the activities. Photocopy them as needed as you work through the activities. Some of the material may be at a higher reading level than your class; if so, feel free to draw out the useful and appropriate information to share with your class.

Where Can I Learn More?

The **Backgrounders** contain basic information about the eight species that are highlighted in this guidebook. You or your students may decide to do further research as you explore the subject. Here are some excellent resources that we have drawn from that can provide you with additional information:

- Klinkenberg, Brian. (Editor) 2008. **E-Flora BC: Electronic Atlas of the Plants of British Columbia** [www.eflora.bc.ca]. Lab for Advanced Spatial Analysis, Department of Geography, University of British Columbia, Vancouver.
- Pojar J. & MacKinnon A. (1994). **Plants of Coastal British Columbia including Washington, Oregon, and Alaska**. Lone Pine Publishing, Vancouver BC.
- **Royal Roads University's Centre for Non-Timber Forest Resources:** cntr.royalroads.ca/

Species Backgrounder 1

Page 1

RED HUCKLEBERRY

Description

Red huckleberry is a common red-fruited bush with very small bright green leaves and stems that grows approximately 1-4 metres tall. It is a deciduous plant (drops its leaves in the fall) that has solitary, tiny yellowish or pinkish flowers. Unlike many other bushes, the stems of red huckleberry are mostly green (older parts turn brown and woody), and are a bit square, or angled, instead of round.

The scientific name for red huckleberry is *Vaccinium parvifolium*. "Vaccinium" means the genus, or group, that this plant is in. There are other plants in the *Vaccinium* group which are all related to the red huckleberry, including blueberries. Many different blueberries are found on the Central Coast of British Columbia including Alaskan blueberry, dwarf blueberry, oval-leaved blueberry, bog blueberry, and mountain cranberry. Blueberries tend to have darker green leaves, blue berries, and browner stems than red huckleberry.



Huckleberry bush

Ecology and Habitat

Red huckleberry is found in a lot of places, from wet to dry forests, bogs and lowland coastal zones. Although they will grow in the shade, they require light to produce berries. Good berry bushes are found most often in clearcuts and young forests, or in mature forests where there are openings in the canopy. A good place to find them is along forest edges, and along streams and lakes. Look for them on rotting logs and stumps.

Species Backgrounder 1

RED HUCKLEBERRY



Deer mouse

Birds, bears, deer and other animals eat the berries of blueberries and huckleberries, helping the plants to spread to new areas.

Economic, Social, and Cultural Importance

Red huckleberries and related blueberries are a valued food source for many British Columbians. The berries can be eaten fresh, frozen, or mashed and then dried.

Red huckleberries are more often collected simply to eat rather than to sell. However, some people do sell wild blueberries and huckleberries. Huckleberry stems are also sold as floral greenery, especially after the leaves drop off in the fall and winter.

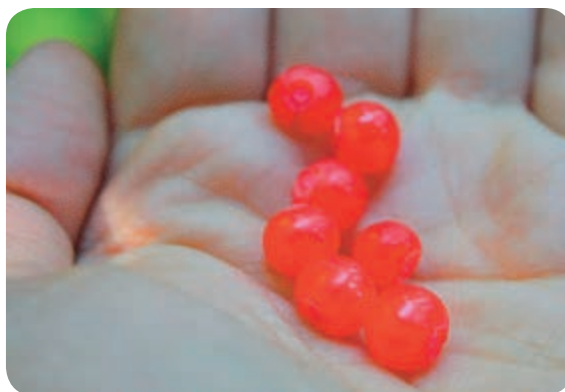

First Nations have used red huckleberries for thousands of years as a food source and as a medicinal food. Traditionally, wooden combs were used to rake the berries off the branches. Some Nations, such as the Tsimshian, boiled the berries with salmon roe in cedar boxes and then sealed the tops of the boxes with eulachon oil (from the eulachon fish) and skunk cabbage leaves. This technique allowed the berries to be kept for many months. Dried berries were stewed and made into sauces, and eaten at winter feasts (Turner, 1995).

The leaves of red huckleberries and other members of the *Vaccinium* genus can also be used fresh or dried to make a healthy and tasty green tea.

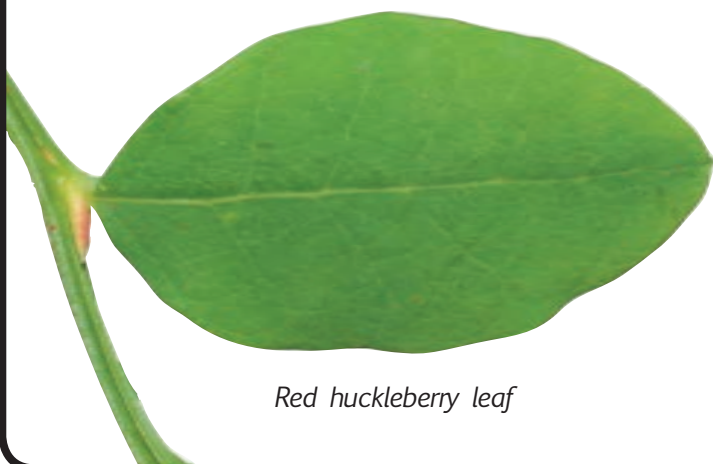

Red huckleberry leaf

Species Backgrounder 2

Page 1

MUSHROOMS

Description

A mushroom is the fruit of a fungus – rather like an apple on an apple tree. With most fungi, the main body (the 'tree') is underground, and all you see are the fruits sticking up. Unlike plants, fungi do not make their own food but have to get it from somewhere else like decaying wood or tree roots.

There are many edible mushrooms that grow in coastal British Columbia, but two of the most popular and economically valuable are the pine mushroom (*Tricholoma magnivelare*) and the chanterelle (*Chanterelle* spp.).

Pine mushrooms have reddish-brown gills and have a strong, unusual spicy, cinnamon odour and taste. Experienced pine mushroom pickers can smell a stand of pine mushrooms even when they can't see them.

Chanterelles are a golden colour, ranging from yellow to orange. They are found throughout the province and are quite a popular edible mushroom because they are delicious to eat and, once you've picked them a few times, easy to identify.

Caution

NO plant or fungus should be eaten as food or medicine unless you are sure of its identity and a reliable source indicates that it is safe to eat. Many mushrooms and plants are poisonous.



Pine mushroom



Chanterelle



Species Backgrounder 2

Page 2

MUSHROOMS

Ecology and Habitat

Pine mushrooms are usually found growing alone or scattered in groups on the forest floor from mid-August to early December, if the conditions are right (enough water and the temperature is right for them to grow). Pine mushrooms mostly need old forests – over 100 years old – in which to grow. The tree species that the pine mushrooms grow with are usually Douglas fir or spruce, and sometimes hemlock or pine.

Chanterelles are found in forests on Vancouver Island, the coastal mainland and Haida Gwaii. Chanterelles like to grow in forests that are about 50-80 years old, with trees such as Douglas fir, hemlock or spruce. They don't like cedar forests very much. They are easiest to find in open forests where there aren't many bushes or ferns growing, but where there is a lot of soft moss. These mushrooms usually come up from August to late November.

Economic, Social, and Cultural Importance



If you added up all the money earned by mushroom pickers, buyers and exporters in British Columbia, the total would be tens of millions of dollars each year. The pine mushroom is the most valuable commercially-harvested mushroom in our province (South Moresby Forest Replacement Account, 2000).

Pine mushrooms are exported only to Japan, while chanterelles and other wild mushrooms are sold mostly to Europe and other parts of North America. Medical research from Asia suggests that many mushrooms can even prevent illnesses or boost human health. This means that we might see even more demand for wild mushrooms in the future, as more people focus on healthy foods (Forrex, 2008).

Pine mushrooms and the related cottonwood mushroom were used as a food by the Interior Salish, Thompson and Lillooet First Nations (Turner, Kuhnlein, & Egger, 1986). More recently, the Nisga'a Nation in northwestern British Columbia developed a forest development plan for the Nisga'a Village Lands that will help protect important harvesting areas for pine mushrooms (South Moresby Forest Replacement Account, 2000).

The Queen Charlotte Culinary Co-operative harvests, dries and sells chanterelles from Haida Gwaii. It is a co-operative that tries to get a better price for local mushroom pickers and to find new markets for dried mushrooms in restaurants.

Species Backgrounder 3

Page 1

LABRADOR TEA

Description

Labrador tea (*Ledum groenlandicum*) is a short shrub, usually 50 - 150 cm tall. The flowers form white umbrellas at the end of each stem of leaves. Each flower has 5 distinct petals. The leaves alternate on the stem of the plant.

The best way to identify Labrador tea is by looking at its leaves. They are up to 6 cm long and are oblong or lance-shaped, with a blunt tip (see the Activity 2 "Learn about Leaf Patterns" for more information on how to identify plants). Each leaf edge is rolled under slightly at the edges. On the underside of Labrador tea leaves there is a covering of rusty, dense hair. If the bottoms of the leaves are fuzzy and rust coloured, it is safe to say it's Labrador tea and not bog-laurel or bog-rosemary, both of which are poisonous. However, it is a good idea to ask a plant expert to be sure you have identified the plant correctly.



Ecology and Habitat

Labrador tea likes to grow in acidic soil, and is found in bogs and wet forests all across British Columbia. It often forms a low canopy in wet forests and provides cover for smaller animals to hide in as they move through open bogs. The plant is often eaten by deer and elk.

Economic, Social, and Cultural Importance

Because of its medicinal qualities, Labrador tea has been traded and used as a remedy for different illnesses over the last 10,000 years (Moore, 1993). Labrador tea has become popular as a modern herbal remedy for colds, chest infections, and fevers. Often it is drunk as a tea or tonic for its spicy taste.

Despite all these uses, Labrador tea is not often sold as a commercial product.

Caution

As with all medicines, you should only make teas and use them under adult supervision.

Species Backgrounder 4

Page 1

DEVIL'S CLUB

Description

Devil's club (*Oplopanax horridus*) is a tall, deciduous shrub with stems approximately 1-3 metres tall, and thick spines 5-10 mm long.

The leaves have 7 or 9 lobes, and they are very large (10-35 cm). The flowers are small and form a greenish-white cone, about 25 cm long. Devil's club berries are bright red small berries that are clumped in small groups. The berries are not edible by humans, but are eaten by bears.

Devil's club can be quite painful, as the spines can act like slivers, irritate your skin and cause a rash.

Ecology and Habitat

Devil's club grows from low-lands up into sub-alpine zones. Devil's club can sometimes be the dominant (most common) species in semi-open forests, especially in wetter areas.

The new shoots and stems of devil's club are edible, but the spines are mildly poisonous.

Economic, Social, and Cultural Importance

Here are some extracts from Lantz, Swerhun & Turner (2004):

Devil's club is rich in value. Not only can it be harvested for food found in its shoots and stems, but it is also considered to be a sacred and spiritual plant. It is used by many First Nations for its healing medicine for a variety of ailments in poultices, teas, and lozenges.

Devil's club is one of the most important spiritual and medicinal plants to many First Nations peoples who live within its habitat. Different parts of this plant are used by over 38 First Nations for over 34 categories of physical ailment, as well as many spiritual applications.



Species Backgrounder 4

DEVIL'S CLUB

Devil's club has traditionally been used for the treatment of external and internal infections. It has been used to treat many ailments including arthritis, broken bones, fevers, headaches, and stomach aches. Several parts of the shrub, including the inner bark, inner bark ash, whole stems, roots, berries, and leaves, are used in a variety of ways for these treatments. The most common type of preparation is a tonic made with the inner bark of the stem.



Devil's club root is used in a variety of ways

Devil's club is also traded commercially and was one of the top five wild harvested herbal medicines sold in British Columbia in the late 1990s (Wills and Lipsey 1999). Many Elders are against the sale of devil's club and other traditional medicines because of the belief that medicines are to be used by all people and should not be bought or sold.

Devil's club is used widely as a spiritual plant. It is important for purification, cleansing and protection against bad external influences.



Devil's club is used to treat many ailments including broken bones!

Caution

As with all medicines, you should only make teas and use them under adult supervision.



Young devil's club shoots with thorns

Species Backgrounder 5

Page 1

PACIFIC YEW

Description

Pacific yew (*Taxus brevifolia*) is a small evergreen tree, growing about 10 to 15 metres tall, with a trunk up to 30 cm in diameter. It has scaly brown bark, with reddish-purple inner bark.

The needles are short, 1-3 cm long. They are dark green on top and lighter underneath, with a white line, and are attached to the branch by small stems called petioles. You can tell a yew from other trees because the needles are very distinctive - they have a pointed tip, and they lay in a flat line off the branch.

The female cones are round and red and poisonous to humans. The cones look like berries (though they are not), and they are about 5-6 mm long and found on the underside of the leaves. The pollen cones (male cones) are yellow, globe-shaped, and about 3 mm long.

Ecology and Habitat

Pacific yew grows happily under the shade of other trees and is often found growing under tall cedars and other evergreens. Yew trees grow slowly, but can live quite long: up to 100 or more years.



Pacific yew grows in forests from southern Alaska through the Pacific Coast region of British Columbia and into Washington. The trees grow in a wide range of forests, with differing moisture and temperature conditions, but grow best in deep, moist, gravel soils. They do well along rivers, mountain streams and in shady canyons and ravines.

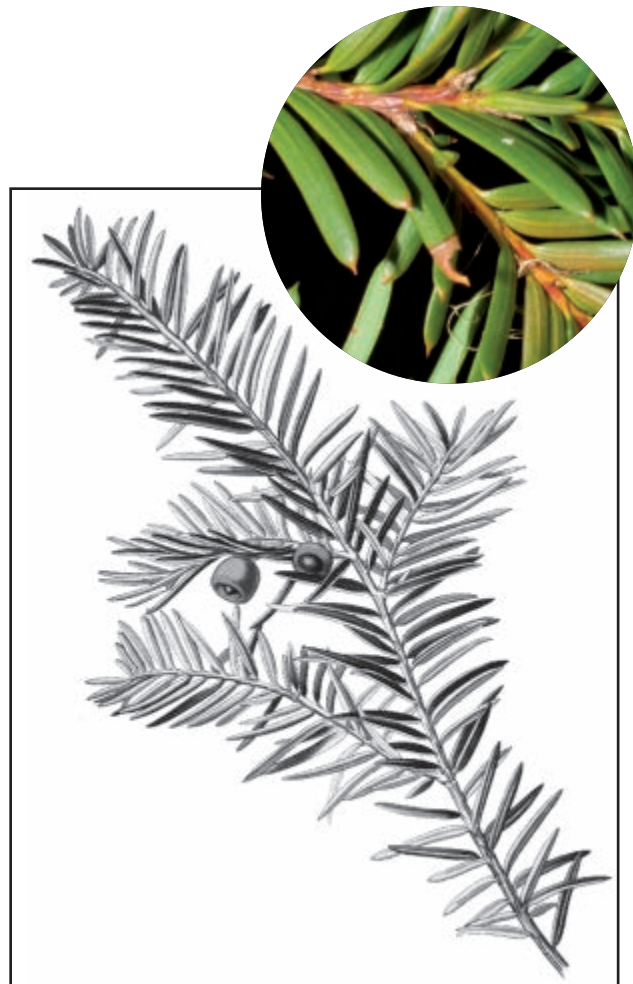

Species Backgrounder 5

Page 2

PACIFIC YEW

Economic, Social and Cultural Importance

Pacific yew has incredibly hard wood in its trunk and branches, and is a valued wood for tools and decorations, especially because of its hardness and ability to hold a high polish. It was named 'the bow plant' by the Haida, Halq'emeylem and Stl'atl'imx, and 'wedge plant' by the Sechelt, Squamish, and Nuu-chah-nulth peoples. Pacific yew can be salvaged from logging sites and is still used by carvers, artists, and regalia-makers today.



Pacific yew bark

In the 1960s, scientists discovered that a chemical compound in yew bark, paclitaxel, had potential for treating cancer. By the 1980s and 90s, yew bark was being harvested in large amounts in British Columbia, leading to concerns over the sustainability of harvesting practices. Since the mid-1990s, other sources of paclitaxel (from other species of yew) have been identified and are being used instead of Pacific yew.



Species Backgrounder 6

Page 1

SALAL

Description

Salal (*Gaultheria shallon*) is among the most common forest shrub in coastal British Columbia. Salal can creep along the ground or stand up to 1.5 metres tall (sometimes even as tall as 5 metres).

It has leathery, tough oval leaves which have slightly pointed ends, and are about 5 to 10 cm long. Its flowers are pink or white bells that hang in rows at the end of the twigs. They bloom in May or June and are hairy looking.

Although salal's fruits look like berries, and are usually called berries, they are not true berries. These fruits are purplish-black at maturity, are hairy and approximately 5-10 mm wide. Salal berries are edible and delicious. They continue to be an important food for many coastal First Nations.



Ecology and Habitat

Salal grows from sea level to mid elevations, and often forms a continuous shrub layer in the ground level of coniferous forests. It is very common along the shoreline throughout most of British Columbia, and is one of the most prolific shrubs on the coast. It grows in dry-to-wet forests.

Salal grows taller in the shade than in very sunny areas, though you need sunny areas to find the fruit. Salal can be found as far north as Alaska.

Species Backgrounder 6

Page 2

SALAL

Economic, Social, and Cultural Importance

In the Pacific Northwest, many people harvest salal to sell to florists worldwide for use as foliage (green part) in flower arrangements. In fact, buyers pay out an estimated \$25 million or more per year for salal stems harvested in British Columbia. Picking salal is hard work but harvesters can earn more money as they gain experience over time.

Because it is a very common and tough plant, there isn't much risk of eliminating stands of salal through over-harvesting. However, some stands close to urban areas on southern Vancouver Island are harvested very heavily, and the plants are never able to grow very tall because of constant picking.

For many First Nations people on the coast, juicy salal berries were the most important and plentiful berry, eaten fresh or dried into cakes and used to sweeten other foods (Pojar & MacKinnon 1994). The Haida used salal berries to thicken salmon eggs. Salal berries are often prepared as jams or preserves.



Species Backgrounder 7

Page 1

SWORD FERN

Description

Sword fern (*Polystichum munitum*) is a large, evergreen fern with long (20-150cm) leaves, or fronds, that are shaped like swords. The pinnae (or smaller leaves) are attached to the frond stem on a small stalk, or petiole, and are pointed and sharp-toothed with a small lobe that points forward at the bottom. Each pinnae looks like a miniature sword.

Ferns reproduce through spores (instead of seeds like many other plants) that are mostly spread by the wind.

Ecology and Habitat

Sword ferns typically are found in wet forests up and down the coast of British Columbia. They are often found growing under western redcedar.

They also can be found in disturbed sites, such as forest clearings or clearcuts, but grow best in some shade. They grow well in wet sites like stream edges or slight depressions.

Economic, Social, and Cultural Importance

Sword ferns are used in a variety of ways. Sword fern leaves are harvested and sold in bundles as floral greenery, though in very small amounts as compared to salal. The sword fern is also popular as an attractive garden plant, and is used in replanting disturbed areas along creeks and on road building sites.

Whole sword ferns can be salvaged from sites for horticulture or ecosystem restoration – particularly when sites are being developed or logging roads are being built. Research conducted on Vancouver Island showed that harvesters salvaging and re-selling ferns that would otherwise be wiped out because of road building or other construction activities can earn money as long as they can find buyers for the ferns (Forest Practices Board, 2004).



Species Backgrounder 8

Page 1

CEDAR

Description

Tall and straight, cedar is integral to life on British Columbia's coast. Two types of cedars grow here: western redcedar (*Thuja plicata*, also called Pacific cedar, giant cedar, tree of life) and yellow-cedar (*Chamaecyparis nootkatensis*, also called Sitka cedar, Nootka cedar). Redcedar is not actually a true cedar, but yellow-cedar, in the *Chamaecyparis* genus, is a true cedar.

Western red and yellow-cedars have many similarities, and are sometimes used for the same purposes. Yellow-cedar wood is slightly more flexible and smooth, but the tree is nowhere near as tall as redcedar, which can be as tall as 60 metres! Both yellow and redcedar branches tend to droop slightly, then turn up at the tips. Redcedar bark is grey to reddish-brown, and yellow-cedar bark is dirty-white to greyish-brown. On both trees, the bark looks a bit shaggy. The two trees can be difficult to tell apart. The redcedar is far more common and is taller. The yellow cedar has a stronger smell, and the needle-covered twigs are quite square (with redcedar they look flat rather than square). Both trees are culturally significant, and the trees are revered as spiritually important because of the close relationships people and entire cultures have with cedar.



Red cedar bark

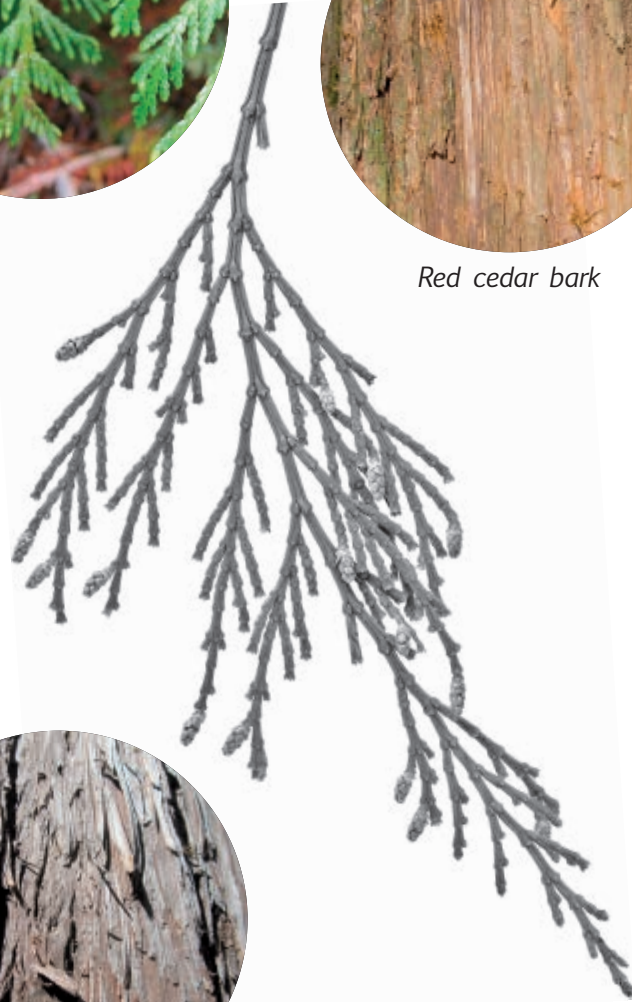

Yellow cedar bark

Species Backgrounder 8

Page 2



CEDAR

Ecology and Habitat

Western redcedar grows throughout coastal British Columbia, with branches drooping into the sea, and up into the hills as high as 1300 metres, from Alaska to northern California. The tallest trees grow in moist soils on cool slopes, lakesides, and river estuaries. Trees that grow in the shade reach up for light, growing tall and straight, with most of the branches at the top. Cedars are often in groves of large trees with an undergrowth of ferns, salal, devil's club and skunk cabbage.

Yellow-cedar grows best on slopes in moist, shaded regions from Alaska to Vancouver Island. It often grows at higher elevations than redcedar. Yellow-cedars are the oldest living trees in British Columbia, with some trees living as long as 1500 years. Redcedars can live up to 1000 years old. One reason both species live so long is because they have an oil in their wood that keeps them from rotting in the damp forest.

Economic, Social, and Cultural Importance

Cedar has been harvested for many thousands of years and is very important to all coastal First Nations: not just to their economy, but also to their way of life, and to their culture. Cedar is held in the highest respect and holds important healing and spiritual powers. In the recent past, peoples of the Northwest Coast made almost everything they needed from cedar: houses, canoes, clothing, ceremonial and house poles, tools and more. Cedar continues to be used for these artistic and cultural purposes.

While cedar has several uses as timber in construction, it also has many non-timber uses. Every part of the cedar – its wood, boughs, bark, roots, leaves and oil, is valuable.

Species Backgrounder 8

Page 3

CEDAR

Cedar wood is used for timber and fine wood for cabinetry and instrument building, as well as for carving, mask-making and other ceremonial art.

Cedar boughs are used to make wreaths and other decorations for holiday celebrations and contribute to a multi-million dollar greenery industry in British Columbia (Forest Practices Board, 2004).

Cedar oil is used in the detergent industry and also as an anti-fungal agent. The oil is extracted from the leaves, and can be removed without affecting the tree's health if bough collection is done properly and in moderation. Some plants have both medicinal and toxic qualities; cedar oil is highly concentrated and contains the toxin *thujone*, so it is not appropriate for use in soaps and body products.



Bowl made from yellow cedar



A woven cedar hat

Weaving with Cedar

For many centuries, First Nations people have woven with cedar bark and roots, making nets, baskets, hats, mats, skirts and many other items. Today, cedar weaving is still an important activity.



Rolls of cedar bark

Species Backgrounder 8

Page 4



A strip of bark removed from a cedar

When bark is pulled off cedar, it is pulled off a living tree, and the tree is not harmed if the harvesting is done correctly. It has the ability to heal itself, although a scar is often left on the tree. It is important to not peel off too much bark from one tree, and to harvest only what is needed. For instance, when the Kwakwaka'wakw pulled bark from a cedar, they took care to leave enough on the tree to ensure its continued growth (Stewart, 1984). It is important to collect strips from young healthy trees and not to collect from too many in one area to reduce the impact on a local stand, and never to collect bark from all sides of the tree at once.

After the bark is stripped from the tree, the outer bark is cleaned away, and the inner bark is used for weaving. The inner bark is soaked and then split or cut into strips. Redcedar bark pulls off in long strips, while yellow-cedar is heavier and softer and pulls off in stiff sections, and can be split into very strong, thin strips. Often they are woven together, and can form a tight weave that can withstand heavy West Coast rains.



Cedar hat, bark and branches



Activities

The activities in this section can be used separately, or linked together to form units. They come in a variety of time-frames. Some will fit easily into one class; others may need to be spread over more than one.

Activity Structure

Each activity is set up like this:

Learning Objectives	What students should be able to do after completing the activity.
Vocabulary	Any scientific vocabulary not specifically defined within the activity is listed here. Definitions for these words are in the Glossary at the back. (Note: In cases where there is no special vocabulary, this section is omitted.)
Time	Overall time required to complete the activity.
Materials	A list of materials needed to do the activity.
Before you start	Additional things to do (besides preparing and collecting materials) to prepare for the activity.
Process	Step-by-step instructions for facilitating the activity.
Evaluation	Suggestions for assessing how well your students have met the learning objectives. The overall evaluation suggestion for this unit is to encourage students to include their work in a portfolio collection, parts of which may be shared with the teacher and/or class at the end.
Extension Suggestions	Additional related activities that build on the basic activity – can be used for either higher grades or more advanced students.
Student Handouts	Handouts used in the classroom activities. At the end of each handout is a series of reflective questions entitled Think About What You Have Learned. These can be used in a number of ways (small group, class discussion, writing, etc.) as a summarizing, reflecting and evaluating tool.



Learning Themes

The activities teach about wild products, how they are used and why they are important, as well as the interconnectedness of forests, and the role that all of us, including students, can play in sustaining wild products and healthy forest ecosystems. Threaded throughout the activities are 5 learning themes:

1. **Conservation and Ecology** – introduction to the values of plants, our relationship with the forest, and sustainable and unsustainable harvesting methods.
2. **Observation Skills** – recognizing patterns in the forest, producing new patterns through crafts and art.
3. **Cultural and Spiritual Significance** – recognizing and respecting shared relationships between species over generations, respecting cultural appropriateness in the use of wild products.
4. **Role of Self** – understanding our role as participants in forest relationships and as protectors and users of the forests.
5. **Economics** – recognizing the value of wild products, considering the balance between economic, cultural, and ecosystem needs.



Activities-at-a-Glance

Getting to Know Wild Species

Activity 1. Get to Know a Plant

Students use their senses to identify one or more species, observe it and draw it. In an extension activity, students go on to learn more about the uses of this species and create a poster using this information.

Activity 2. Learn about Leaf Patterns

Students use information about leaf features to identify similarities and differences between salal and huckleberry leaves.

Activity 3. Make a Plant Map

Students map a small area near the school, with emphasis on location of plant species, and then – in Part 2 of the activity – extend their mapping to include a wider area of their community.

Activity 4. Thanks for the Plants

Students review the characteristics of a wild product they have studied, consider how some of the plant's characteristics might be ones shared by humans, and identify reasons to be thankful for the plant.

Wild Edibles

Activity 5. How to Sustain Ecosystems

Through reading and discussing two short articles, students learn about ecosystems and sustainable harvesting. They discuss a harvesting situation in their own community, and make a poster about ecosystems and sustainability.

Activity 6. The Forest Food Web Game

Through a food web simulation game, students learn the importance of maintaining a balance within the food web.

Activity 7. Making a Seasonal Harvest Calendar

Students, with the help of a community resource person, create a large wall calendar of the forest foods harvested throughout the year by their community. The visitor speaks to the students about past and present harvesting practices. Students take notes, ask questions, and create a thank-you note to summarize what they have learned.

Activity 8. Gathering Berries for Jam

Students sustainably harvest salal berries, learn about the ways that people in their community use these berries for food, then prepare and eat jam.

Activity 9. The Business of Mushrooms

Students do research, using the internet and asking family members, to gather the information they would need before starting a small mushroom-picking business.

Medicinal Uses

Activity 10. Learning about Devil's Club

Students interview a community member, either in the classroom or as a homework assignment. To prepare for the interview, they read background information, and then prepare questions to find out more about how devil's club is used in their own community.

Activity 11. Making Tea

Students are led by a community resource person on a field trip to collect tea leaves from huckleberry, Labrador tea, and possibly other plants. They listen to stories about tea leaf collection, preparation, and use, and then prepare a tea.

Floral Greenery

Activity 12. Making Wreaths

Students sustainably harvest boughs of salal and cedar and use them to make wreaths.

Crafts and Art

Activity 13. Cedar Weaving

Students learn the basics of weaving using construction paper, and think about how they might extend this to include natural materials. In a suggested extension, a community weaver demonstrates and tells stories about weaving.

Activity 14. Cedar Stories

Students interview community resource people about old and new stories of cedar, and present these stories to the class. In an extension activity, they consider the symbols used in cedar carving, and create a personal ceremonial pole.

Wrap-Up

Activity 15. Wild Products Fair

Students organize and present to the school and community a fair that features all that they have learned about wild products.

Creating a Portfolio

Each of the 15 activities includes an evaluation suggestion. However, as well as using these individual evaluation techniques, you may want to invite your students to create a Wild Products portfolio. As you go through the activities, you will notice that many of them involve creating a product: artwork, reports, maps, reflections, etc. If students collect these, you will have a complete record of work for each of your students. (**Note:** for evaluation purposes, you may invite students to submit their 3 favourite pieces of work, etc.)

If you also collect the larger group- or class-created pieces such as murals, mega-maps, etc., you will be a step ahead if you decide to hold a **Wild Products Fair** as a wrap-up (Activity 15).

Taking your Classroom Outside

A trip into the forest or into other natural surroundings is a chance to study the environment first hand and will enhance your students' learning experience. This guidebook suggests several activities that will take your students beyond the four walls of the classroom. Depending on where your school is located, this may mean a simple walk from the school grounds, or a more major field trip. For reminders, instructions and tips, go to **Appendix B: Field Trip Checklist**.

Working in Small Groups

Many of these activities include small group work. Students at this level generally work well in groups, but need to know how to organize themselves. If you feel your students need help in structuring themselves in small groups, try using the student handout in **Appendix C: Working in a Small Group**.



ACTIVITY 1. Get to Know a Plant

Learning Objectives:

- Recognize plant patterns by using different senses
- Identify specific wild species
- Practice observation and drawing skills

Vocabulary:

non-timber forest products (NTFPs)
wild products
species
habitat

Time:

30 minutes - 1.5 hours

Materials:

- paper or art-books
- coloured pens and pencils
- collected natural materials
- copies of *Student Handout 1: Get to Know a Plant!*
- Copies of **Species Backgrounders** of the plants you have chosen (a few of each)

Before you start:

Search out several plant species close to the school or gather an assortment of clippings. If possible, choose plants covered in the **Species Backgrounders**.

Process:

1. Distribute copies of *Student Handout 1: Get to Know a Plant!* Go over them together.
2. If this is an outside activity, lead your students on a walkabout to see the species you have chosen to focus on. Encourage the students to note the names of each of the plants. If it is an inside activity, show the class the plant clippings you have collected. Arrange these in different locations in the classroom.
3. Explain that all of these plants are wild products – they are plants that grow in the forest that are gathered for food, medicine, crafts and art, or floral greenery. Sometimes these are called Non-Timber Forest Products (NTFPs), because they are products of the forest – other than trees cut for timber – that have value and are used by people.
4. Distribute blank sheets of paper, or ask students to use their art books.
5. Invite students to sit down in a comfortable quiet spot separate from each other, and to follow the instructions in *Student Handout 1: Get to Know a Plant!* Make copies of the appropriate *Species Backgrounders* available to students.

Evaluation:

You may decide to use the *Think About What You Have Learned* questions at the bottom on the student handout in various ways: writing down the answers, sharing their answers with a partner (either with a partner who has drawn the same plant, or a partner who has drawn a different plant), sharing them in small group or in full-class discussion.

Extension Suggestions:

Make a Species Poster

Group the students in same-species groups, and ask them to use their drawings and the **Species Backgrounder** to create a poster on their species and its uses as a wild product.

Invite students to include their work in their **Wild Products portfolio**.

STUDENT HANDOUT 1

Get to Know a Plant!

Here's a chance to get to know a plant that is important in your community. Before you start, here are three tips on how to draw plants. Drawing a plant is easier than you think.

Take your time.

Before you start, you might want to take a few minutes to really look at your plant carefully, and then to think about how you want to fit it onto your page.

Try to really see this plant.

Draw what you actually see, not what you think a plant should look like.

Move around to see the plant from different angles.

You may find you like one view better than another.

Steps to follow:

1. At the top of your blank sheet of paper, write the name of your plant.
2. Draw the entire plant. What does the top of the plant look like? The middle? The bottom? What do the roots look like?
3. Draw an individual branch. What shape are the leaves? How are they arranged? Are there cones, fruits, or flowers?
4. Close your eyes and feel the plant. What does it feel like? Under your drawing or on another piece of paper, write some words that describe the feel (e.g. is it rough? dry? soft?).
5. Smell the plant. How does it smell? Write some words that describe the smell.
6. Find out some more about your plant. If you are outside observing your plant, write about its habitat – where does it like to grow? If you are indoors, your teacher will give you some background information. Write down some words to describe the habitat of your plant.

Think About What You Have Learned:

Think about these questions. (Your teacher may ask you to write down the answers, or may ask you to think about them, so you can share your answers with someone else.)

- What features stand out when you look at the plant as a whole (e.g., shape, colour, fruit)? What features stand out when you look at parts of it up close?
- If someone wanted to find this species in the forest, what things would you tell them to help them find it? (**Hint:** Think about the plant's features and also its habitat.)



Activity 2. Learn about Leaf Patterns

Learning Objectives:

- Explain leaf features used to identify and differentiate plants, using vocabulary relating to leaf structure and placement
- Explain the importance of correctly identifying plants used for edible purposes

Vocabulary:

coniferous

Time:

1 hour

Materials:

- cuttings of salal and huckleberry (Note: If these are not obtainable, other leaf-bearing wild plants can be used)
- copies of *Student Handout 2: Leaf Patterns*
- pencils or pens

Before you start:

If your students are not accustomed to working independently in small groups, you may have to go over the group roles with them. See *Appendix C: Working in a Small Group*, for more information.

Process:

1. Distribute copies of *Student Handout 2: Leaf Patterns*.
2. Go through it together.
3. Divide students into groups of 2 to 4, each with a cutting of huckleberry and salal, and be available for help as they work through the instructions.

Evaluation:

Ask each student to choose a different partner (not in their original group) and tell this person 3 important similarities and 3 important differences between salal and huckleberry leaves.

Invite students to include their lists in their **Wild Products portfolio**.

Extension Suggestions:

Illustrate a Leaf

Ask students to choose either one of the two plants they examined, and to draw a small section of leaves (enough to show placement) clearly enough so that someone else could use their drawing as an identification guide.



STUDENT HANDOUT 2

Leaf Patterns

When picking plants, it is important to pick the proper plant, especially if you are picking food. Sometimes plants can look like other plants that are not good to eat and might even be poisonous. Plants have particular patterns, and in order to properly identify plants, it is important to know what patterns to look for.

Leaf Features to Look For:

Leaf Shape



Circular



Egg-shaped



Lanceolate



Heart-shaped



Lobed

Veins



Parallel



Pinnate



Palmate

Leaf Edges



Smooth



Toothed

Growth Patterns



Opposite



Alternate

STUDENT HANDOUT 2

SALAL



How to identify salal:

In order to find salal, you first need to look in a place where it would grow. It tends to grow in forests underneath large conifer trees. Salal usually grows with other salal plants, covering all of the forest floor in some places. You can also identify salal by its specific characteristics:



- Salal leaves are alternate.
- Salal leaves are leathery.
- Salal leaves are egg-shaped.
- If it is spring or early summer, there might be flowers. Salal flowers are white or pink, and hang like little bells in rows.
- If it is late in the summer, there might be berries. Salal berries are dark blue or purple.
- Salal berries are about 5 to 10 millimetres across.

HUCKLEBERRY

How to identify huckleberry:

To find red huckleberry, look at the edges of coniferous forests.

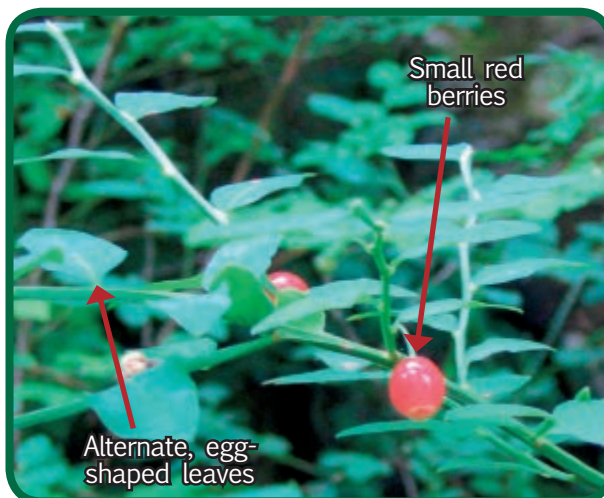

- Huckleberry leaves are alternate.
- Huckleberry leaves are egg-shaped, often more narrow ovals.
- Huckleberry leaves are not toothed.
- If it is spring, there might be flowers. Huckleberry flowers are small yellowish green or pinkish bells.
- If it is late summer, there might be berries. Huckleberries are small and red and sour but tasty!



STUDENT HANDOUT 2

Finding Similarities and Differences:

Use this worksheet to help to find similarities (the things that are the same or almost the same) and differences between these two plants, salal and huckleberry.

Similarities

5 features that these leaves have in common (**Hint:** Look at the Leaf Features chart above, but also think about features like colour, smell, hairiness, spots, thinness, thickness, toughness, etc.):

1. _____
2. _____
3. _____
4. _____
5. _____

Differences

5 ways that these leaves are different from each other:

1. _____
2. _____
3. _____
4. _____
5. _____

Think About What You Have Learned:

- Why is it important to pay close attention to all these leaf features when you are gathering wild plants?

- What new words did you learn to describe leaves? (Write down at least 3.)



Activity 3. Make a Plant Map

Learning Objectives:

- Use observation skills to identify plants
- Create a simple map of features, including wild products, near the school community
- Explain the significance of mapping
- Describe the importance of 'special areas' where populations of plant species grow

Vocabulary:

species

Time:

1.5 - 4 hours (if both sections are done) - could lead to continued work during the school year

Materials:

- paper or a journal
- clipboards (Note: these can be made from pieces of board or cardboard, and a clip)
- pens, pencils and erasers
- coloured pens and pencils
- town map (Note: if your school is on-reserve the band office should have a map of the reserve if you can't find one)
- copies of *Student Handout 3, Part 1: Make a Plant Map*
- copies of *Student Handout 3, Part 2: Make a Bigger Map* (if you decide to move on to Part 2)

Before you start:

Walk around and choose an outdoor location to start your students on mapping. It should be a space with lots of natural features, and enough different spots so that you can divide the students into groups and give them different ground to cover.

This activity is in 2 parts. Part 1 involves the initial development of simple mapping skills through a nearby mapping venue. Part 2 involves mapping of the larger community. Plan how you will structure this work. If you decide to go on to Part 2, you may decide to assign the Part 2 rough mapping as homework.

Process:

Part 1

1. Introduce your students to the idea of mapping by displaying a map of their town and inviting them to find their home.
2. **Ask:** If we wanted to draw a map of our classroom, what would we need to draw? Follow student suggestions to quickly create a map of desks, location of various furniture, reading corner, etc. Make sure you label these as well as sketching them in.
3. Distribute copies of *Student Handout 3, Part 1: Make a Plant Map* and go over them together.
4. Make sure students have the materials they need: clipboards, paper, pencils, erasers.
5. Take your students outside, assign areas and get them mapping. Tell them that they will have 20 minutes to create a map of their area. Keep reassuring them that what they are creating is a rough diagram, and that they can do a better version once they return to the classroom.
6. Once back in the classroom, give students time to work on "good copies", either individually or in pairs. Post these on the wall.

Part 2

If possible, challenge your students to stretch a little further by moving on to *Student Handout 3, Part 2: Make a Bigger Map*. Consider assigning the rough draft for homework, and then give class time for students to work on the final map version.

Evaluation:**For both Part 1 and Part 2:**

- Invite students to post their completed maps around the room, and have a *Map Gallery Walk-around*. At each map, invite one of the students to ask its creator a question about his or her map.
- You may also want to use the Thinking about what you have learned questions, either in pair, group, or class discussion.
- When the maps finally come off the wall, invite students to include them in their Wild Products portfolio.

Extension Suggestions:**Dynamic Wall Map**

The maps can be put on the wall and added to throughout the year, with natural items (leaves, twigs, etc.) glued to the map in appropriate places. Students can add species, geographic features they have found, and other items over the year. These maps can be updated, changed, and coloured. Encourage your students to find a new addition to their map every week!

Mega-Maps

Create a mural-sized map that different students can contribute to, using their smaller maps as a reference. This is a project that students can work on in extra time, after they have completed their required work.

Micro-Maps

Ask your students to draw a zoomed-in map of the cedar bark or branches. What significant sites exist on the bark? Can you see what routes the ants take to walk up and down the tree? Or zoom into other plant species - where do they grow? Are there specific plants that often grow with them? If so, do they always grow together?

More Mapping Resources:

Barefoot Mapping is a type of ecosystem mapping that does not require fancy tools or specialized knowledge, and takes into account all of the natural and human-made features of our home area. Did these activities whet your appetite for more barefoot mapping? If so, check out two of Sierra Club BC's learning resource guides:

- *Barefoot Mapping* (2001)
- *From Maps to Murrelets: An Introductory Guide* (1998)

Both are available for free download from the Sierra Club BC's Education website (www.sierraclub.bc.ca/education), and can also be purchased in hard copy.

More information on maps can also be found in the resource *Giving the Land a Voice: Mapping our Home Places*. You can order this book from the Land Trust Alliance of British Columbia: <http://www.landtrustalliance.bc.ca>.

STUDENT HANDOUT 3

Make a Plant Map

One good way to look closely at the plants in your neighbourhood is to make a map. A map is a type of diagram of an area. It shows what things are in an area, and it shows where they are located.

When you go outdoors to map an area, remember that what you are doing is making a rough draft. Your map doesn't have to be perfect. Think of yourself as a bird, looking down from the sky. What would this bird see?



Steps to follow:

1. Walk around the area you are planning to map, and look for the main features:
 - Very large things like buildings, roads and paths
 - Large things like trees, big rocks, hills, or logs
 - Plants, patches of mushrooms or moss. Make sure you label these with a name if possible.
 - Places where animals might live
2. Figure out approximately how big you can draw the features you have seen, and still have room on your page. It might be useful to make a little mark for each large feature, before you really start to draw.
3. Draw a small sketch or symbol of each thing you see, and also write its name. Because you're outside and just making a rough copy, don't worry about being perfect. (Note: If you see a plant you don't know the name for, ask someone else or draw a little sketch of the plant to help you ask your teacher later.)
4. When you get back into your classroom, use your coloured pencils or pens to make a more perfect and colourful version of your map.

Think About What You Have Learned:

Think about these questions. (Your teacher may ask you to write down the answers, or may ask you to think about them and share your answers with someone else.)

- What plants did you see?
- Were there some plants that you couldn't recognize? Can you describe or sketch them so that someone else may be able to tell you what they are?
- Why is it important to be able to make maps and understand maps?

STUDENT HANDOUT 3

Make a Bigger Map

Now that you have experience as a map maker, try making a map of a larger area. This time, draw a map of your community. (Imagine you are still a bird, but this time you're flying much higher than you were in Part 1.)



Try to include:

- the school grounds
- forest
- hills
- wetlands (rivers, lakes, puddles, etc.)
- specific plants (cedar, yew, huckleberry, other berries, devil's club etc)
- routes (to get to and from home, to get to the plants, etc.)
- places along the way (stores, your house, your friends' houses, playing fields, etc.)

Remember to use a little picture, or logo, for each feature, and to label it if possible. You may even want to pick a small bit of the plant (e.g., a leaf) to paste on your map to show where you found that plant.

Bring your map to school, and be prepared to explain it to someone else.

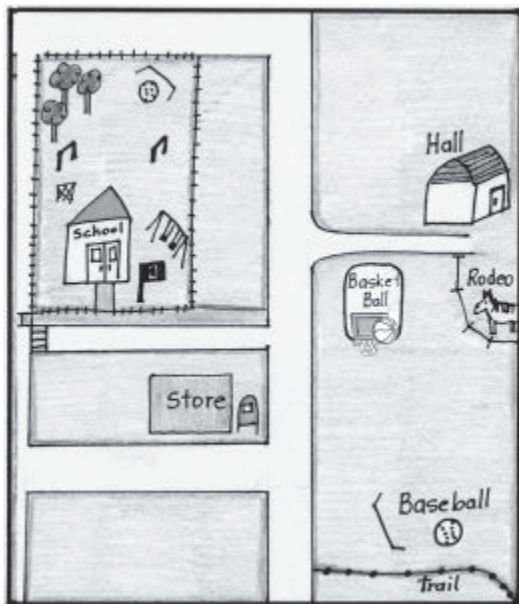

Think about what you have learned:

- What species (plants) are easy to find in your community?
- Are there any special areas where there are many different kinds of species (plants)?
- Is there anything that might impact these special areas? (e.g. new houses being built, garbage, use of ATVs, logging, climate change)
- What things could your community do to help protect these special areas?



Activity 4. Thanks for Plants

(Summary Activity)

Learning Objectives:

- Identify and generalize the characteristics of plants
- Identify reasons to be thankful for the plants students have studied

Time:

30 minutes

Materials:

- samples of wild products, previous creations (maps, sculptures, etc.) (optional)
- sheet of paper and pencil for each student



Process:

If possible, sit the students (with paper and pencil) in a circle, with samples of the wild products studied in the centre.

1. Tell the students that today you are going to think about the *characteristics* of each of these wild products. Hold up a sample (e.g., salal), and brainstorm its characteristics, writing them on the board (e.g. green, thick, leathery, tough, strong, grows everywhere). Explain that these characteristics are all the things that are special about this plant.
2. Ask students to think about the wild product that they feel they have learned the most about, and write a list of its characteristics. Tell them that they will have 5 minutes to create their lists.
3. Go around the circle and ask a few students to share their lists. Then ask the students to go through their list and to put a star next to any characteristic that they share with their plant. Ask which are their favourite characteristics and why.
4. After 2 or 3 minutes, ask them to turn to the person on their left, and to share with that person what characteristic they chose, and why.
5. Now, ask your students: *Can you think of any reasons we should be thankful for the plant that you have chosen?* Give them a minute or two to write down a reason to be thankful for their plant.
6. Go around the circle and ask students to share their reason for being thankful.

Evaluation:

Thanks, Plants! Graffiti Poster

Post a large, mural-sized sheet of paper on the wall. On it, tape pictures of each of the wild products you have studied, arranged with lots of space between them. Provide coloured markers. Invite students to write messages of thanks to one or more of the plants, and to sign their messages. (Note: This can be done over a period of a few days, to avoid congestion).



Activity 5. How to Sustain Ecosystems

Learning Objectives:

- Explain the concepts of ecosystem and sustainable harvesting practices
- Use art skills to present ideas of ecosystem sustainability

Vocabulary:

ecosystem
sustainable harvesting
over-harvesting
natural resources

Timeline:

1.5 hours

Materials:

- large pieces of paper, writing and drawing implements
- copies of *Student Handout 5: How to Sustain Ecosystems*

Before you start:

If your students are not accustomed to working independently in small groups, you may decide to go over the group roles with them. See *Appendix C: Working in a Small Group*, for more information.

Decide how you will structure the work. Will you assign both mini-articles to each group? Or will half the groups work on *Mini-article 1 (Harvesting Pacific Yew)*, and the other half *Mini-article 2 (Harvesting Huckleberries)*?

Process:

1. On the board, write the words *ecosystem* and *sustainable harvest*. Briefly brainstorm what the students already know about each of these terms.
2. Distribute copies of *Student Handout 5: How to Sustain Ecosystems*.
3. Ask a student to read aloud the section: *What is an Ecosystem?* At the conclusion, ask if there are other words you should write in your brainstorm list on ecosystems.
4. Repeat this process with *What is Sustainable Harvesting?*
5. Go over the rest of the handout. (Leave the mini-articles to be read by the students in their small groups.) Make sure everyone understands the task.
6. Ask the students to form groups of 3 or 4, and give each of them a large sheet of paper and art materials. Clarify the mini-articles you would like them to read and discuss, and the timeline.
7. Create a gallery of the completed posters, and walk around as a class. Invite each group to explain their posters and answer questions.

Evaluation:

Use the completed posters, and the group's explanation of them, to make sure that students understand the concepts of ecosystem and sustainable harvesting.

Extension Suggestion:

Ask the groups of students to create a skit that shows the importance of sustainable harvesting, both for the continuation of the plant species, and for the well-being of the other species who are part of the ecosystem. You can either ask the groups to choose whether they will base their skit on the Pacific yew or huckleberry harvest, or you can assign these topics.

Give the groups 20 minutes to plan their skits, then all sit round and enjoy the presentations.

STUDENT HANDOUT 5

How to Sustain Ecosystems

What is an Ecosystem?

An **ecosystem** can be as small as a puddle or as large as the coastal temperate rainforest. Any group of living and nonliving things interacting with each other can be considered an ecosystem. So you can think of an ecosystem as a community of animals (fish, birds, insects, humans, and everyone else), plants, water, soil, and other resources in an area. Everything that lives in an ecosystem depends on the other species and elements that are part of their community. If one part of an ecosystem is damaged or disappears, it has an impact on everything else. Because nature is always changing (living things grow and die, temperatures go up and down, weather changes, etc.), ecosystems are always balancing.



What is Sustainable Harvesting?

Sustainable harvesting is when you don't take too much of any one species. You harvest in a way that does not disrupt the balance in an ecosystem. If too much of one species is picked too quickly, it may not be able to grow back, and the ecosystem may not be able to recover.

The opposite of sustainable harvesting is over-harvesting, when too much is taken for the ecosystem to adapt and be healthy. To avoid over-harvesting, it is important to take note of what you are picking. Are there many plants? Do you need to take the entire plant, or would one branch or a few leaves be enough? Are you leaving enough berries for the birds and animals?

Think About Harvesting: Before you start, choose a facilitator, a reader, a recorder and a timekeeper. Your teacher will tell you which article or articles you should work on. Listen as the reader reads aloud. As you listen, think about sustainable harvest. *What happens when a species is over-harvested? How can this be avoided?*

STUDENT HANDOUT 5

Mini-Article 1: Harvesting Pacific yew

Pacific yew has been used by First Nations for thousands of years because it is a very hard wood with a nice polish and is useful for building tools and decorations. In the 1960s,



Spoons carved from Pacific yew

western scientists discovered that a chemical compound in yew bark, paclitaxel, had potential for treating cancer. The bark, needles and twigs of Pacific yew contain taxanes. These taxanes could be made into paclitaxel, a very strong anti-cancer drug. Suddenly, Pacific yew was in great demand. In the 1990s, people

could make lots of money by harvesting it and selling it to drug companies. During the next 10 years, there was so much harvesting of Pacific yew that it became very hard to find on the west coast of BC. **So much yew had been taken that it would take a long time to grow back.**

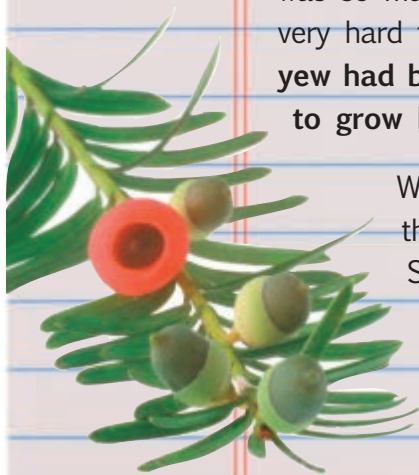

Pacific yew

What could the drug companies do, now that the Pacific yew was becoming harder to find? Scientists explored the forest some more, and found another plant that contained taxanes. Now, ground hemlock (*Taxus canadensis*) from eastern Canada is the main source of paclitaxel.

Here's the question:

How can communities make sure that this plant is harvested sustainably, so that it can re-grow and keep producing this important drug?

STUDENT HANDOUT 5

Mini-Article 2: Harvesting Huckleberries

Huckleberries



Fred Sampson heads out in his truck from his home on the Siska reserve, near Lytton, to the Coquihalla high country, where he's going to collect some huckleberries. Sampson, chief of the Siska First Nation, remembers making this journey when he was a small child. His family went to Merritt by truck, where they met his grandparents, and they completed the last leg of the trip by horse and buggy along a dirt road, years before the Coquihalla Highway existed. It was two weeks of family time; the men hunted deer, which was smoked and dried in the camp, while Sampson picked the tasty huckleberries by hand with his aunts, uncles, and older brother, putting them into cedar-root baskets.

When Sampson returned to the site of his traditional camp last July, he saw a large van parked by the side of the road and a dozen people in the bushes. Commercial huckleberry pickers were using rakes to scoop the berries off the bushes and into plastic buckets.

"We got there and there were no berries," Sampson says. "They cleaned the area out. They use rakes that take the leaves off the plant while it's still in photosynthesis. When I saw this, at first, I felt anger, then just plain sadness...."

Nowadays, the Siska First Nation has started a company called Siska Traditions, to collect huckleberries. They use the traditional method of sustainable harvesting: they only take 30% of the berries in order to leave some for the birds and bears and to nourish the huckleberry plants. They also collect arnica flowers, wild mint, dandelion, yarrow, plantain, devil's club, wild ginger, juniper, and stinging nettle for use in teas, soaps, jams and jellies, and herbal medicines.



Arnica

Adapted from Efron, S., *Marketing of Forest Floor Has Consequences*, Georgia Straight, Dec. 9, 2004.

STUDENT HANDOUT 5

Discuss:

When you have finished reading the article, discuss these questions. Your recorder should take very brief notes on your main ideas.

1. What types of wild products or other natural resources are harvested from your territory?
2. What are some of the other animal and plant members of the ecosystem that are affected by the harvest?
3. Is the harvest sustainable? How could the harvest be improved to help sustain the ecosystem?

Make a Poster:

Use the art materials to create a poster that shows the main things you have discussed. You may decide to make 2 posters: one showing over-harvesting of an ecosystem, and the effects this has on other members of the ecosystem, and one showing sustainable harvesting. You may decide to use only pictures, or you may want to include words. It's up to you!

Note: Make sure you can explain your poster (or posters) to others in your class.

Over-harvesting



Sustainable Harvesting

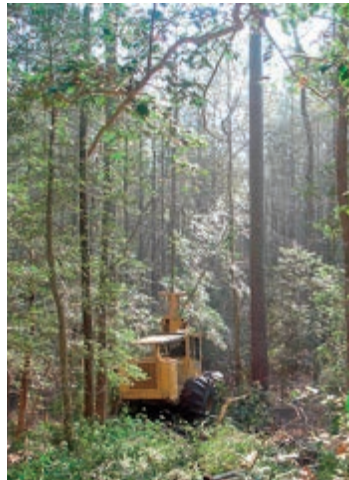

Think About What You Have Learned:

- Why is it so important to sustain ecosystems?
- What can you do to help sustain ecosystems in your territory?



Activity 6. The Forest Food Web Game

Learning Objectives:

- Explain the meaning and importance of food webs, ecosystems, and sustainability
- Describe ecological interconnectedness and the balancing nature of ecosystems

Vocabulary

ecosystem
food web
habitat
over-population
sustainable

Time:

1 hour

Materials:

- a set of food cards (see *Round 1* instructions, and *Forest Food Web Cards* page at the end of this activity)
- copies of *Student Handout 6: The Forest Food Web Game*
- paper and pens

Before you start:

Decide on the space for the game. Outdoors or in the gym may work best, unless you have a large classroom.

Process:

1. Distribute copies of *Student Handout 6: The Forest Food Web Game*. Read the Introduction. Ask: *What happens when there are too many humans or animals that eat certain plants?*
2. Explain that the students are going to play a game that will teach them more about the food web, and the way in which all the players in an ecosystem —plants, animals and humans — are interconnected.
3. **Round 1:** Hand out the cards. Give about a fifth of your class each type of card (omitting deer cards). E.g., If there are 20 students in your class, hand out 4 human cards, 4 food cards, 4 medicine cards, 4 tool cards, and 4 art cards. If your class number isn't a multiple of 5, give one extra of each non-human card, so that the children with the 'human' cards will be able to collect one of each of the other types, and there will be several left over. Read student handout for more detailed instructions.
4. **Round 2:** Collect the cards, and hand them out again, but this time, hand out 2 more human cards, 1 less food card, and 1 less medicine card. This time it will not work out that each human gets all four categories.
5. At the end of Round 2, ask the following questions:
 - What happened? Did all humans find what they needed? Why not?
 - What happens when humans take too much?
 - Are any plants left? Which ones?
 - Are there times like this in the forest, when some plants get collected and there are not enough for others? Why?
 - Are there things that humans can do to make sure that plant resources are shared?

6. **Round 3:** Collect the cards again. This time, add in 3 deer cards. Then shuffle the rest of the cards (human, food, medicine, tools, art), and give out the 3 deer cards, plus the random assortment of shuffled cards.
7. Debrief the game posing the following questions:
 - What happened in this round? What was different?
 - What happens if there are more deer? What happens if there are fewer?
 - Are deer the only animal needing plants for food? Who else needs them?
 - How can humans and animals and plants live in the forest together?
8. Tell your students the *Deer in Haida Gwaii* example below. What would need to happen in Haida Gwaii to restore the natural balance of the ecosystem?

Deer in Haida Gwaii.

Deer were introduced to Haida Gwaii early last century and since then the islands have become overpopulated with deer due to the few predators that eat deer on the islands. These deer have an enormous impact when they overgraze local plants. They have reduced the available food and medicinal plants that are used by the Haida people.

Evaluation:

Pose the question: *How has this game changed your thinking?* Ask students to turn to a partner and discuss the answer to this question, or to write it down.

Extension Suggestions:**Sharing stories and traditional knowledge**

Invite students to tell their families about the activity and ask family members for stories of over-harvesting and imbalance in their communities.

These stories can be shared orally with the class, or form the basis of a written report or illustration. (See *Activity 14: Cedar Stories*, for suggestions about preparing for interviews.)

STUDENT HANDOUT 6

The Forest Food Web Game

Introduction:

Have a look at this diagram (sometimes called a 'Food Web'). What does it show you?

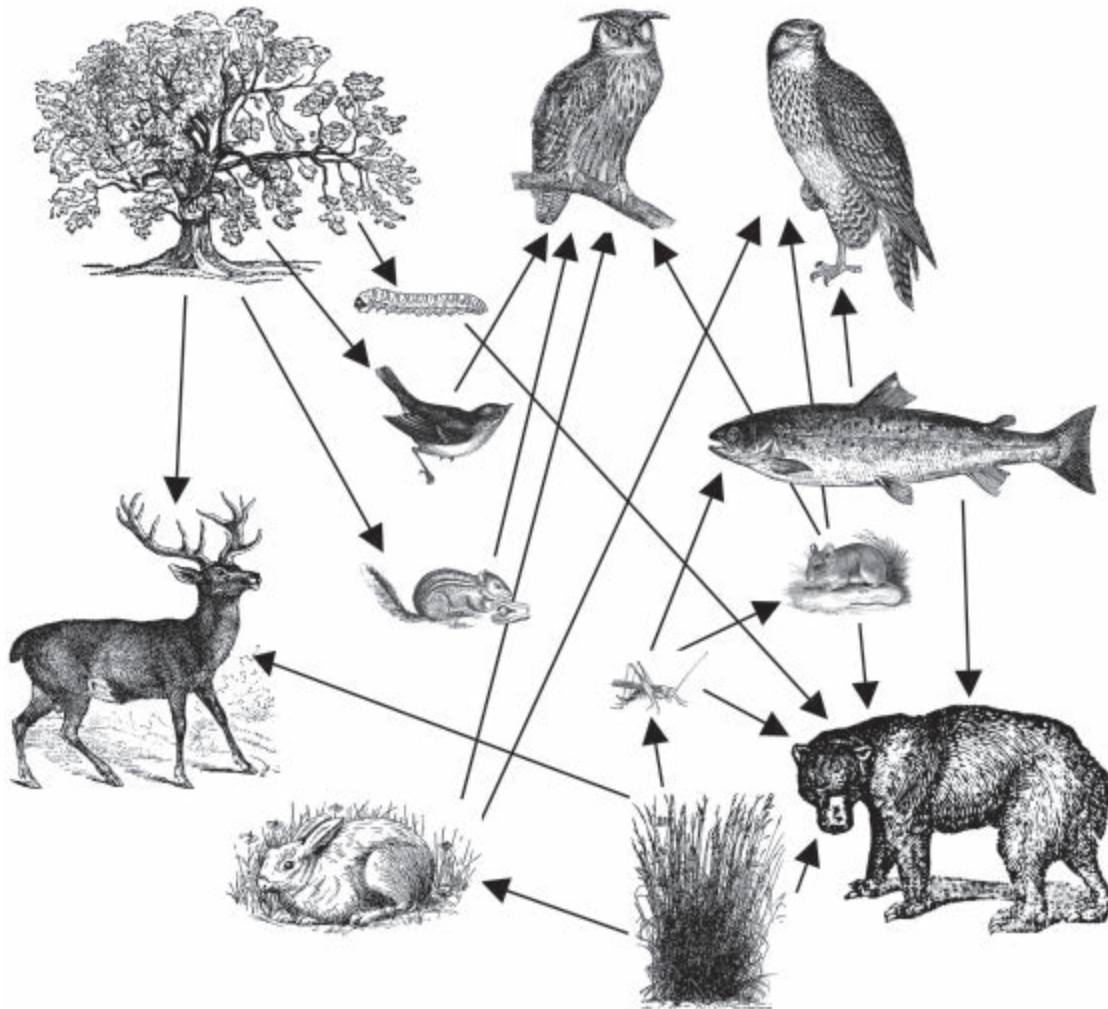

What do you think will happen when one element in this web changes (e.g., gets over-harvested)? What animals or plants would you change about this food web to make it apply to your community?

You are about to play a game that will teach you more about food webs, and why they are important.

STUDENT HANDOUT 6

Rules:

There are 5 types of cards in this game: food cards, medicine cards, tool cards, art cards, and human cards. Your teacher will give you a card. Make sure you hide it from everyone else. Take a minute to read your card, so that you understand what its use is.

Round 1: If you have a food, medicine, tool or art card, find a space where you're not right next to anyone else.

If you have a human card, you have to collect a plant for each of the following:

1. food
2. medicine
3. tools
4. art

You must collect them in this order (e.g., food first, then medicine, etc.). The humans need to ask a person "Are you Food?" and if they say "yes" they link arms and go to look for Medicine. If they say "no" the human must keep looking for food.

Once the human has all four, they are finished and can sit down.

Round 2: Repeat the process.

Round 3: Repeat the process, but this time some people will get deer cards. Deer have to run around with the humans, trying to collect food cards, but not the medicine, tools and art cards. They will continue doing this until the humans have met all of their needs (and sit down) or until the food cards run out.

Think About What You Have Learned:

- What have you learned from the **Forest Food Web Game**?
- What can you do in your community to help sustain the food web so that there is enough for all?

STUDENT HANDOUT 6

Forest Food Web Cards

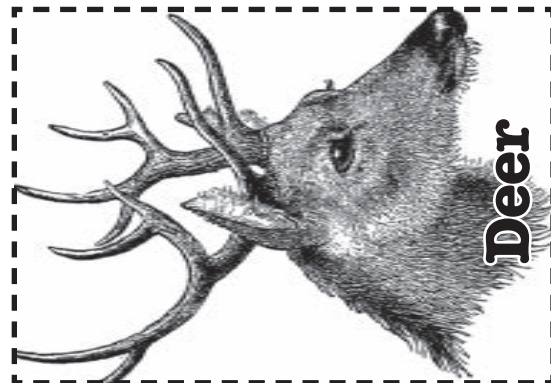
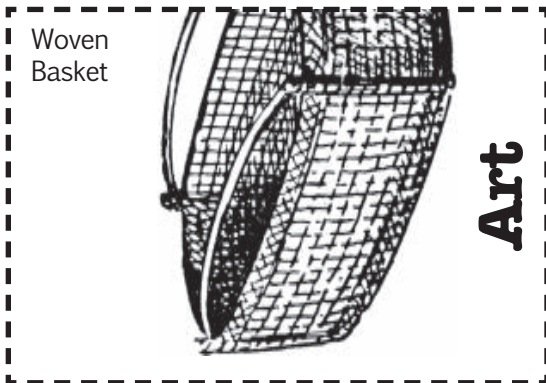
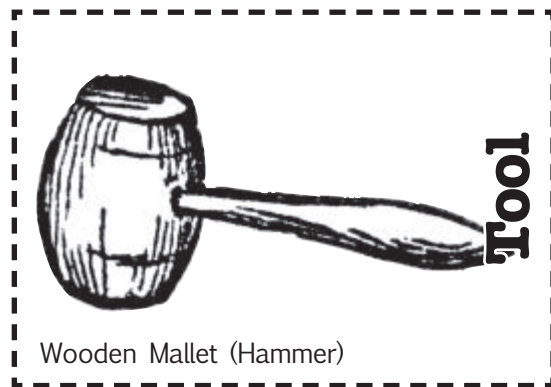
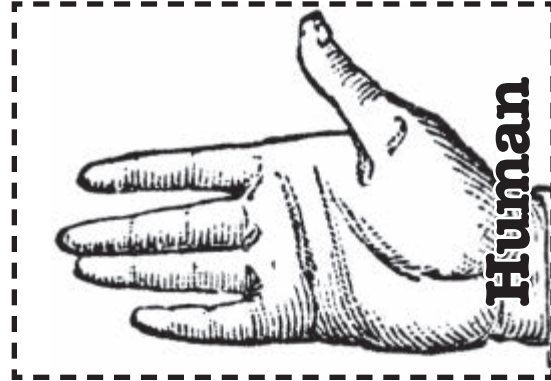

Activity 7. Making a Seasonal Harvest Calendar

Learning Objectives:

- Identify the season for harvesting various wild products in the territory
- Describe traditional harvest methods and uses of wild products in the area

Time:

1 hour

Materials:

- large sheet of chart paper (perhaps more than one sheet taped together) and felt markers
- large stickies, or sheets of paper and tape
- notebooks and pens or pencils

Before you start:

Invite an Elder or other community resource person with knowledge of past and present practices to speak on the wild products traditionally gathered for food in your territory. Ideally, the resource person you invite to work with your class will be able to speak to some or all of these topics:

1. Different foods that are harvested at different times of year.
2. Moving around to follow the plant harvest season.
3. Methods of preserving wild products.
4. Traditional practices for harvesting plants. How did they make sure the harvest was sustainable?
5. Obtaining some wild products through trade with other people.
6. Stories from their own childhood. What do they remember about gathering and preparing wild foods as a child?

Tell your students about the visitor who will be coming, and invite them to make a list of questions they would like to ask him or her.

Identify a student to thank the visitor at the end of the presentation.

Process:

1. Introduce your community resource person, and explain to the class that s/he will be helping you learn about the wild products traditionally used for food in your area.
2. On a large sheet of paper draw a large circle with an "X" in it.
3. Mark each season (winter, spring, summer, fall) in the four quadrants of the circle, with winter on top.
4. Before the speaker begins, ask the students if they know what time of year when any important plants or animals are harvested. Write these on your large stickies or separate pieces of paper and stick them to the seasonal wheel.
5. Invite your visitor to speak and encourage them to make additions or changes to the seasonal wheel, building on the students' brainstorming. Ask your students to take notes of anything that stands out for them, and of any questions that they would like to ask at the end. Add more onto the seasonal harvesting chart after listening to the speaker.
6. Ask the student who has prepared a thank-you to thank the visitor.



Evaluation:

Invite students to write a thank-you letter to the visitor, identifying at least one new thing they learned, and one thing they really enjoyed about the presentation.

Extension Suggestion:

Transform your Seasonal Harvest Calendar from rough copy to final copy by inviting students to make pictures of the different wild products to be pasted onto the calendar next to the name of the product.



Activity 8. Gathering Berries for Jam

A fall harvest activity (September/October)

Learning Objectives:

- Identify and gather wild berries
- Describe what is fun and challenging about berry picking
- Identify local ways that salal berries are used for food
- Follow recipe instructions to prepare berry jam

Time:

2 hours

Materials:

- copies of *Species Backgrounder 6: Salal*
- copies of *Student Handout 8: Making Salal Berry Jam* or locally-collected recipe (see *Step 1* below)
- buckets for collecting berries (ice-cream buckets, yogurt containers or water bottles all work well)
- if making jam at school, jam-making supplies: large pot, stove, and ingredients (see recipes below)
- crackers or bread to spread with jam and eat

Before you start:

- Locate an appropriate place to harvest salal berries.
- Invite a local community member to help you (optional) or other adults to supervise the class while berry picking.
- Decide how you will structure your jam-making session. Is it practical to do it at school? Could you do this activity in the morning and then make the jam at lunch time with students who wanted to help? Would it be an idea to freeze some berries to make more jam later (e.g. at the Wild Products Fair, if you decide to have one)?
- *Step 1* (optional) involves gathering local recipes and ideas for using salal berries. You may want to do this well ahead, collect and print the recipes.

Process:

A few days ahead (option):

1. Write on the board: *salal berries*. Ask: How many of you like to eat them? What are some ways we can use salal berries as food? Brainstorm a list. (Answers might include: raw, mixed with other fruit, in muffins or pancakes, jam, etc.) Ask students to quiz their families on good ways to use salal berries, and to bring descriptions and recipes back to school. You may decide to use one of these recipes, rather than the jam recipe in *Student Handout 8: Making Salal Berry Jam*.

Berry-picking day

1. Distribute copies of *Species Backgrounder 6: Salal*. Remind students that it's important to correctly identify plants if they are planning to eat the berries. If you have already done *Activity 2: Learn about Leaf Patterns* with your class, review the characteristics of the salal leaf to help with identification.
2. Remind students of sustainable harvesting practices. It's important to leave some berries in each part of the salal patch. Ask your students why this is important.
3. When you return with your harvest, either make jam or if you don't have access to a stove, eat the berries! (Note: If you make jam, you may choose to use *Student Handout 8: Making Salal Berry Jam*, or use another recipe.)



Evaluation:

After returning from berry picking and making jam, invite students to work in two or threes and brainstorm a list of what they liked about harvesting the berries and making jam, and what they found difficult. Ask each group to share their ideas and record these on the board.

Extension Suggestions:**A Berry-Picker's Life**

Ask students to write a story on a day in the life of a berry-picker. They should cover the following elements (print these questions or write them on the board):

- How far would they have to go?
- What types of berries would be picked and how would the picker identify them?
- How long would it take to pick an ice cream bucket's worth of berries?
- How does the berry picker determine a good berry? (hint – taste, colour, size, time of year, proximity to road)
- What does it feel like to be a berry-picker?
- How would they carry lots of berries?
- Do they sell them and how much for?
- What types of foods could be made with berries?



Berry baskets with Oregon grape, salal, blackberries and rosehips

STUDENT HANDOUT 8

Making Salal Berry Jam

Here are 2 jam recipes using salal berries. **Make sure you have an adult to help you**, and have fun!

Salal Berry Jam 1

Ingredients:

- 4 cups ripe salal berries, cleaned
- 2 apples (tart if possible), peeled and diced
- 1 cup sugar, or more to taste
- small amount of water (up to ½ cup)
- Optional – package of Certo or other pectin crystals, just in case the jam doesn't thicken enough

Process:

1. Crush one layer of berries at a time in a large pot with a potato masher.
2. Turn the heat on to medium and add the apples.
3. When the mixture is boiling, add the sugar and a small amount of water if it seems that the mixture might stick to the pot.
4. Cook at medium heat until the jam thickens (20-30 minutes).

Now try your jam on some bread or toast and see what you think! You made your very own jam with wild products from the forest.

Salal Berry Jam 2

Ingredients:

- 12 cups salal berries, cleaned
- ¾ teaspoon lemon juice
- 4 tablespoons sugar, or more (to taste)

Process:

1. In a large saucepan over medium-high heat, cook berries until soft. Strain through a fine-mesh sieve or cheesecloth to extract all the juice.
2. Return berry juice to the saucepan over medium heat, add lemon juice and sugar to taste and cook until sugar is dissolved. Cook until mixture starts to jell (about 5 minutes).
3. Cool and eat.

Notes: Though the berries are strained to extract the juice, this resembles jam more than jelly. The amount of sugar in the recipe is very low because salal berries have natural pectin, so sugar is not necessary for thickening but you can add more sugar for a sweeter jam.

Note: If you decide you want to bottle either of these jams, you will need more equipment (for canning instructions, google “making jam”). Rather than canning the jam so that it can be stored over time, you can keep your jam in the fridge and eat it all up quickly.



Activity 9. The Business of Mushrooms

Learning Objectives:

- Use research and summary skills to locate and organize information about the role of mushrooms in small-scale businesses on the coast
- Create a basic business plan for harvesting and selling a wild product
- Explain the economic worth of wild products

Vocabulary:

business plan

Time:

2 hours (including homework)

Materials:

- images of mushrooms and mushroom pickers
- copies of *Species Backgrounder 2: Mushrooms*
- copies of *Student Handout 9: Finding Out about Mushrooms*

Before you start:

Read through the activity and decide how you will structure the work. Is it realistic to ask your students to do this for homework? Is adequate internet access available, or would it be better to invite someone from the community to answer questions? (Note: This activity is most appropriate for higher grades – grade 7 and up.)

Process:

1. Explain that today the focus is mushrooms. Ask students what they know about wild mushroom harvesting in the area. Does their family gather mushrooms? Do they know someone who harvests and sells mushrooms? What kinds of mushrooms are common in their region? Is mushroom-picking a good way to make money?
2. Display any images you have of local mushrooms and mushroom picking, and discuss them.
3. Hand out copies of *Species Backgrounder 2: Mushrooms* and read together the section entitled *Economic, Social, and Cultural Importance*. Stress that the mushroom-picking business brings lots of money into the BC economy.
4. Ask: *What about starting your own mushroom-picking business? Have you ever thought about it? What would you need to find out first, before you were ready to start?*
5. Hand out copies of *Student Handout 9: Finding Out about Mushrooms*. Go over it together, then assign it for class work or homework.
6. When the students have completed their handouts, invite presentations. Discuss differences and commonalities. Use the *Think About What You Have Learned* questions as discussion-organizers.

Evaluation:

Invite students to include their completed handouts in their portfolios.

Extension Suggestions:**Invite a Mushroom Business Owner to your Class**

If there's someone in your community who has gone through the process of starting up and managing a mushroom-picking business, invite them to your class. Ask students to use their research to help them prepare questions in advance.

STUDENT HANDOUT 9

Finding Out about Mushrooms

The wild mushroom business in British Columbia is big business. It gives many people in small communities part-time or seasonal jobs.

In this activity, you will use your research skills to find out more about how to harvest mushrooms, and start a small business. Here are some ideas about where to go to find the information:

People in Your Community:

Do you have a family member or neighbour who knows about mushrooms?

Websites:

Here are some websites with lots of information about mushrooms in British Columbia:

<http://bcmushrooms.forrex.org/>

<http://bcbiodiversity.homestead.com/mushrooms.html>

www.for.gov.bc.ca/hfp/publications/00028/harvest.htm

<http://cntr.royalroads.ca/files-cntr/File/Harvester%20Handbook%20for%20web%20Aug%202008.pdf>

Caution

Never pick or eat mushrooms unless you have an experienced mushroom picker with you who can positively identify mushrooms!

Some mushrooms can look fine or like other mushrooms, but are poisonous and deadly to eat. CAUTION!!!



Pine mushroom

STUDENT HANDOUT 9

Starting a Mushroom Business

If you want to start a small mushroom business, you'll need some information first. If you answer the questions below, you'll have the basic information to get you going. Good luck!

1. What mushrooms are edible in your area? (give two to three examples)

2. Are there qualities about these mushrooms that make them easy to sell? (e.g., Do they taste good? Can they be preserved?)

3. When and how would you harvest these mushrooms?

4. What tools would you need to do this?

5. Who would you sell these mushrooms to? (Give specific examples.)

6. What would you do to ensure that you can continue to pick mushrooms in the future? (What picking techniques would you use to make sure there would be enough mushrooms next year? Where would you pick and not pick?)

7. What makes a mushroom business difficult? What challenges come with building a business?

Think About What You Have Learned:

- What did you learn about the wild mushroom business that you didn't know before?
- Can you see yourself as the owner of a mushroom-picking business? What would you like about it? What would you dislike?
- How can your community ensure that there will always be enough mushrooms?

Activity 10. Learning about Devil's Club

Learning Objectives:

- Formulate questions about medicinal and spiritual uses of plants
- Describe the medicinal and spiritual uses of devil's club and their cultural importance

Time:

2 hours

Materials:

- devil's club images or plants
- copies of *Species Backgrounder 4: Devil's Club*
- copies of *Student Handout 10: How Devil's Club is Used in Our Community*

Before you start:

Find out whether it is appropriate to discuss devil's club with your class, and – if so – who are the community resource people you can ask to help with this activity? Decide how you will structure the work. Some options are:

- Students, either singly or in pairs, interview community members with a knowledge of past and present uses of devil's club
- Students prepare questions for a community visitor whom you invite to the classroom to speak and respond to questions about devil's club

Process:

1. Introduce devil's club. Hold up a picture, ask students where it grows and what they know about it.
2. Distribute copies of *Species Backgrounder 4: Devil's Club*. Read through it together.
3. Explain that students are going to have the opportunity to learn more about how devil's club is used in their community, and outline how they're going to do this (interviews, class visitor, etc.).
4. Distribute copies of *Student Handout 10: How Devil's Club is Used in Our Community*. Go through it together. You may find it helpful to brainstorm one set of questions, to encourage students to formulate their own.
5. When students have had a chance to ask their questions and take notes (either through separate interviews or through a class visit), ask each to report a separate fact or story that most impressed them (making sure it's different from what earlier students have recounted).

Evaluation:

Ask students to write a mini-report or story on what interested them, and arrange these on a bulletin board, surrounding a picture of devil's club.

Invite them to include their questions, answers, and mini-reports in their portfolios.



STUDENT HANDOUT 10

How Devil's Club is Used in Our Community

In this activity, you will have the chance to talk to someone in your community about how devil's club has been used in the past, and is being used now.

Plan Your Interview:

Your teacher will either invite a speaker to your class, or help you to decide on a person to interview.

Name of person: _____

Be prepared! Make sure you have:

- this student handout
- a notebook or pieces of paper, and a pen or pencil

Questions to Ask:

Medicinal Uses

In Alaska, devil's club is sometimes called the "*Tlingit aspirin*". Members of the Tlingit First Nation use devil's club for everything from coughs and colds to stomach ulcers.

Think about what you'd like to know about how devil's club is used for medicine in your community:

- In past times
- In present times

Write down 2 questions you'd like to ask:

1. _____
2. _____

STUDENT HANDOUT 10

Spiritual Uses

Devil's club has been used by many coastal people to protect against evil and disease. There are also many traditional stories about devil's club.

Think about what you'd like to know about the spiritual uses of devil's club in your community:

- In past times
- In present times

Write down 2 questions you'd like to ask:

1. _____
2. _____

Attitude

Some people consider devil's club a weed. What do the Elders in your community think about devil's club? Do they think it is a plant that should be respected?

Write down 1 question you'd like to ask about your community's attitude towards devil's club.

1. _____

Are there stories about devil's club in your community? How can you find out?

Write down 1 question you'd like to ask:

1. _____

Think About What You Have Learned:

- What was the most important thing you learned about devil's club?
- Will you think about devil's club differently now? Why or why not?



Activity 11. Making Tea

Learning Objectives

- Identify, collect, prepare and use wild tea leaves
- Discuss the spiritual and cultural significance of medicinal uses of plants

Time:

2 hours

Materials:

- dried tea leaves (such as Labrador tea) - *optional*
- copies of Species Backgrounders 1 and 3, on red huckleberry and Labrador tea
- map of town
- clip boards, paper, and pens or pencils (Note: clip boards may be constructed from pieces of heavy cardboard or thin wood, with a clip.)
- camera
- safety supplies for field trip
- electric kettle, teapot, and mugs
- honey to sweeten the tea (*optional*)

Before you start:

- Contact the band office for maps of the area and see if there are people in the community with knowledge of the location of Labrador tea and other tea plants.
- Talk to someone knowledgeable about gathering to identify the best time to gather the leaves, and an appropriate site to travel to. Note: You may be able to travel to more than one site, and gather at least 2 types of tea leaves.
- Invite one or more community resource people to lead you.
- If you are going to an area far from your school, organize transportation, permission forms if necessary, supplies, etc. (For information on organizing field trips, see *Appendix B: Field Trip Checklist*.)

Process:

1. Show the students a map of the local area and invite them to point out any features that they are familiar with. If they know where people go to harvest food plants, ask them to draw those places on the map. Point out where you will be travelling to on this field trip.
2. Outline the safety and other protocols involved in preparing students for a field trip and introduce the community people traveling with the students.
3. Pose the question: *How can we make sure we harvest in a sustainable way?* Collect answers on the board. Make sure students are aware that they shouldn't take too many leaves from one plant and that they should be careful about where they step.
4. Before you leave, hand out clipboards, copies of the 2 plant backgrounders, and sheets of paper. Explain that the backgrounders will help students be sure they are identifying these species correctly, and the blank paper is for notes or questions.
5. Under the guidance of your community resource person, collect leaves using sustainability principles. Try to collect more than one type of leaf (e.g., Labrador tea and huckleberry).
6. When you return from your collection trip, invite the community resource person to talk to you about the best way to prepare the leaves to make good tea. He or she may also have some stories of collecting tea leaves in days past. Invite your students to ask questions.
7. You may want to make tea on your return (if you have some previously-dried tea leaves), or you may decide to wait until the leaves you collected have dried.
8. When the tea leaves are ready, make tea! See instructions for making Labrador tea and other types of tea below.

Evaluation:

Ask your students to write a short article on what it was like to gather leaves for tea and drink tea made from the leaves they had gathered. Some of these stories, accompanied by photos, may be sent to the local newspaper, or submitted to your school newsletter.

Making Tea:

Making Labrador tea

If possible allow the leaves to dry over a week in the sun.

Preparation: Leaves or Flowers

To make a tea rich in Vitamin C, steep one heaping teaspoonful of Labrador tea leaves or flowers per person in boiling water for 5 minutes. The colour should be a clear, pale amber-orange. It can also be used to stretch black tea for a more aromatic drink.

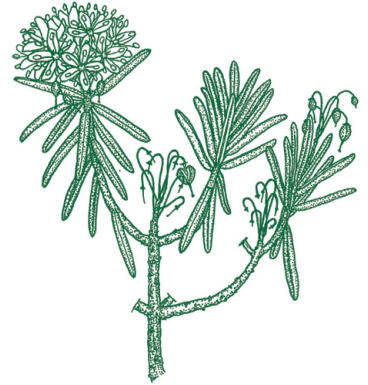

Caution

CAUTION: The leaves look somewhat similar to several toxic plants that are related. The key identifying feature of Labrador tea is the dense rusty hairs on the underside of the leaf, while the other plants do not have the same type of hair on the leaves. Ask a reliable source to confirm you have the right leaves.



Making Spruce Tea (*Picea sitchensis*)

Habitat

Spruce is present throughout British Columbia; Sitka spruce is prevalent on Haida Gwaii (Queen Charlotte Islands) as well as the west coast of British Columbia.

Available: Year-round

Preparation: Needles

Gather spruce needles, can be used either *fresh* or *dried*. Steep them in boiling water for a good 10 minutes for a flavorful drink.

Notes

Spruce needles can be sharp, use caution when gathering needles for tea.



Making Wild Mint Tea

(Mentha arvensis)

Habitat

Moist areas, including stream banks & lake shores, also found among the long grasses of a low lying meadow.

Available: Spring - Fall

Preparation: Leaves

Fresh leaves: Crush and steep the fresh leaves for 5 to 10 minutes. One handful will make a standard pot of tea.

Dry leaves: 1 heaping teaspoonful per 1 cup of boiling water.

Notes

Other species of mint include peppermint and spearmint. Wild mint is native to the West Coast.

Making Huckleberry Tea

(Vaccinium parvifolium, Vaccinium membranaceum & other species)

Habitat

Different varieties of these berries are available throughout BC, including damp, shaded coastal forests to high mountain elevation in full sun in the interior.

Available: Late Summer to Early Fall

Preparation: Berries or Leaves

Berries: Pour three cups of boiling water over half a cup of either fresh or dried berries, steep for 10 -15 minutes.

Leaves: steep 1 handful of crushed green leaves per 2 cups boiling water; steep for flavor. Add honey to taste.

Notes

Watch for wildlife; bears enjoy huckleberries as much as humans.



References

Stewart, Hilary. (2002). *Drink in the Wild: Teas, Cordials, Jams and More*. Vancouver, B.C.: Douglas and McIntyre.

Peterson, Lee Allen. (1977). *A Field Guide to Edible Wild Plants, Eastern/Central North America*. Boston: Houghton Mifflin Company.

Activity 12. Making Wreaths

Learning Objectives:

- Identify and sustainably harvest wild products suitable for floral greenery
- Create a work of art using local materials

Vocabulary:

sustainable harvesting

Time:

1.5 hours

Materials:

- copies of *Student Handout 12: Greenery Harvesting Guide*
- tape measures or rulers (a few to share)
- bags to carry the branches
- shears (gardener's scissors)
- camera
- bendable wire – pre-cut to 1 m length – one length for each student (you can use straightened old wire coat hangers but they're not as easy to work with)
- green twist-ties

Before you start:

- Locate an appropriate place to harvest salal and cedar boughs.
- Invite a local community member to help you.
- Identify a student to thank your visitor.

Process:

1. If you have invited a local resource person, introduce him or her.
2. Explain to your students that they are going to be collecting salal and cedar branches, using sustainable harvesting methods, and making wreaths.
3. Distribute copies of *Student Handout 12: Greenery Harvesting Guide*. Go through it together.
4. Distribute collection bags.
5. Divide students into groups of 3 to 4, giving each a tape measure.
6. Go out and collect your boughs.
7. Return to the classroom to make the wreaths.

Evaluation:

Create a Photo-Essay

Take pictures of each stage of wreath-making: welcoming your visitor, preparing to go out, collecting, making the wreaths, holding the completed wreaths. Post these along a bulletin board, and invite students to choose one stage of the process to write a paragraph about. Post these paragraphs under the related photo. (Note: This photo-essay may be the basis of an article you send to your local newspaper or community newsletter.)

Extension Suggestion:

Use these wreaths as a fundraiser to finance a field-trip later in the year. Support the students developing a business plan to sell the wreaths or have a holiday gathering where the wreaths are up for auction. Develop a list of the costs involved in making the wreaths, and determine an appropriate selling price to recoup the costs.

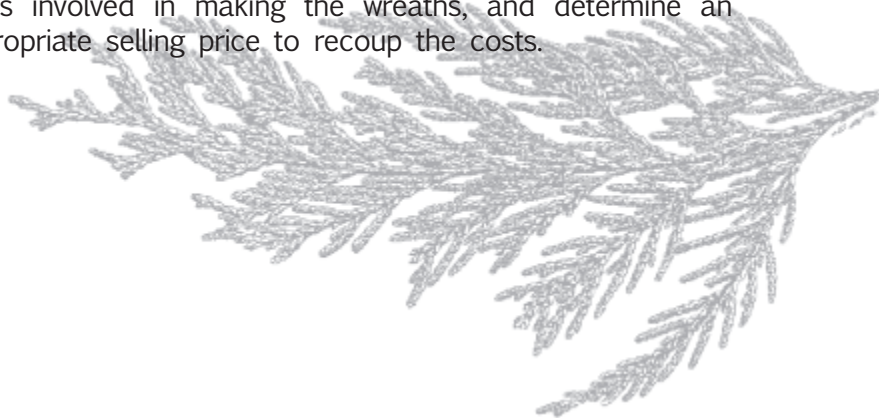

STUDENT HANDOUT 12

Greenery Harvesting Guide

How to harvest sustainably

When you harvest your branches, you want to make sure that you don't take so much off one plant that you injure it. And you want to make sure that you don't take so many plants that you injure the ecosystem (the community of plants and animals that live here).

Here are some pointers to help you harvest sustainably:

- Harvest only what is sustainable for the plant and for the area. Refer to the Harvesters Handbook for guidance on how to harvest floral greenery and other NTFPs (download at: <http://cntr.royalroads.ca/files-cntr/File/Harvester%20Handbook%20for%20web%20Aug%202008.pdf>)
- Be aware of the ecosystem. Some plants, such as mosses, provide homes and food for entire communities of plants and animals so watch where you step!
- Never harvest large amounts of any plant from one area. The rule of thumb is to harvest no more than 25 percent of a plant or its foliage from a site. If there are very few plants in an area, don't harvest them.

(based on the *Centre for Non-Timber Resources'* guide)

Harvesting Salal Branches

Break the branch off near the base of the stem. Each salal branch should be approximately 50 cm long.

The branches should be branched ("sprays"). The leaves should be free from blemishes, "rust", fungus, or insect bites. Woody brown stems are to be avoided.



Salal branches

STUDENT HANDOUT 12

Harvesting Cedar Branches

Cut boughs approximately 60 cm long. Do not over-harvest the branches on a tree; just take a few of the lower branches.

It is best to find a cluster of younger trees (10–25 years), for easier access to boughs and better quality. Ensure you have permission to cut the branches from the tree.

Harvesting Other Plants

You may notice other plants, such as huckleberry, that would also look good in a wreath. You can collect a few of these branches, too, as long as you're careful to take just one or two branches from each plant. You may find other things on the forest floor like pinecones or old twigs that you might also want to add to your wreath – more wild products!

Make Your Wreath

Use a circle of wire as the base of the wreath. Weave the salal and cedar branches around the wire and use the green twist-ties to secure them to the wire. If you have enough branches – even some without a lot of leaves on them – you can use them right next to the wire to make a nice thick base for the greenery added afterwards.

Check the Centre for Non-Timber Resources website for more information on making wreaths and other products: <http://cntr.rovalroads.ca>.



A wreath made of cedar and other conifers



Activity 13 - Cedar Weaving

Learning Objectives:

- Demonstrate basic weaving skills
- Explore the cultural and spiritual significance of cedar trees

Time:

1.5 hours

Materials:

- paper, art-book, journal
- coloured pens and pencils
- scissors
- strips of cedar bark (optional)
- copies of *Species Backgrounder 8: Cedar*
- copies of *Student Handout 13: Step-by-Step Weaving*
- examples or pictures of objects woven from cedar

Before you start:

You may want to invite a knowledgeable community member to assist in presenting this activity. Community members may have stories or songs to share about weaving, or offer general stories of traditional and modern uses of cedar. A weaving demonstration would be an excellent way to kick off or wrap up this activity.

Process:

1. Ask students if they have had or know anyone who has had any experience collecting or weaving with cedar. Show them examples or pictures of items made of woven cedar. Explain that today they will be learning about the importance of cedar, and the basics of how to weave.
2. Hand out copies of *Species Backgrounder 8: Cedar*.
3. Divide students into groups of 3 -5, making sure they take with them a pencil, paper or notebook, ruler, and scissors. Ask them to read the section of the backgrounder on *Economic, Social and Cultural Importance*, paying special attention to the part entitled *Weaving with Cedar*. (Depending on the reading level of your students, you may want to assign a reader for each group, or ask students to read silently.)
4. On the board, write these 2 questions:
 - Why is the cedar an important tree?
 - What do you think weavers might need to know about gathering cedar bark?
5. Ask the students to choose a facilitator and a recorder, and to spend 5 minutes discussing these questions, and preparing answers for the whole group. (Note: For suggestions on working effectively in small groups, see *Appendix C: Working in a Small Group*.)
6. Draw the attention of the groups together, and ask for reports from the recorders (depending on time, you may decide to ask for only a few responses).
7. It's time to weave! Give each group enough copies of *Student Handout 13: Step-by-Step Weaving*, and construction paper.
8. Go over the instructions all together, then give the students time to work through the process on their own.

NOTE: some students might have sensitivities to cedar oil which comes from cedar bark. A reaction can occur with excessive touching of bark, leaves etc. However, this is unlikely to happen as a result of this activity.

Evaluation:

If students are creating a Wild Products portfolio, invite students to include their weaving, along with a short written statement about how they felt about the weaving, or the importance of cedar in weaving. You may also want to post these on a classroom wall, or in the school corridor.

Extension Suggestions:**Weaving Demonstration**

Invite local weavers to demonstrate their work, and to give students weaving tips. Invite them to talk about the materials they use and their views on the commerce and value of their products.

Encourage a discussion about the different markets that are interested in traditional basketry – who is buying traditional baskets? How much do they generally sell for? How long does it take to weave a basket and prepare all the materials?

Using Wild Materials

Ask a local weaver to take your class on a gathering trip. What weaving fibres can be found in the nearby area? If cedar is one of them, your expert may be able to demonstrate sustainable harvest of cedar bark, and give your students a few strips with which to start weaving.



Woven cedar hat with cedar bark and branches

STUDENT HANDOUT 13

Step-by-Step Weaving

If you follow these instructions carefully, you'll be a beginning-level weaver. After you have learned to weave using paper, you may decide to try your hand at using natural materials. There are all kinds of natural materials that can be woven (bark, kelp, grasses). But remember to harvest in a sustainable way – ask an adult to help you.

Weaving Steps:

1. Fold a piece of coloured construction paper in half.

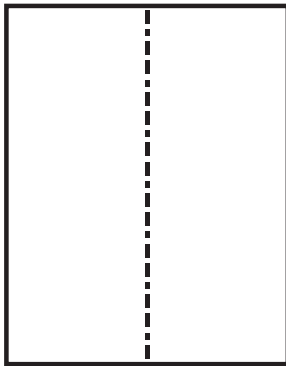

2. Use a ruler to draw a faint line 1 cm from the side edge.

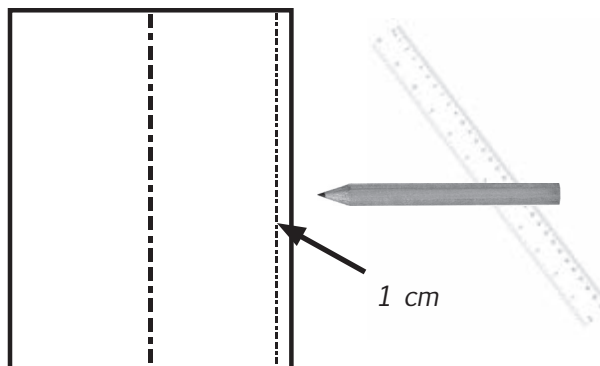

3. Cut slits every 3 cm, beginning each slit at the folded edge and cutting to your faint line.

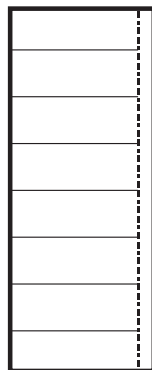

STUDENT HANDOUT 13

So that, when the paper is unfolded, it looks like this:

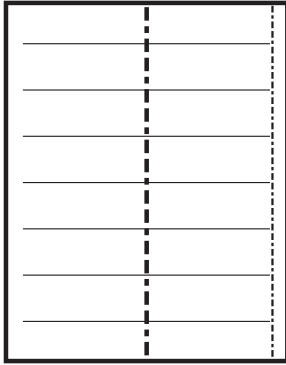

This is called the “warp”.

- Using another piece of construction paper (preferably a different colour), cut strips 3 cm wide. Weave these in and out of the warp. These horizontal strips are called the weft (or woof). The weft goes *over* one part of the warp, then *under* the next part. The next strip goes *under* and then *over*, and so on. When you finish, you shouldn't be able to see through – you will have a solid, beautiful piece of weaving! *What can you do with your weaving?* Try bending it slightly. *How would you change your weaving if you wanted to make basket?*

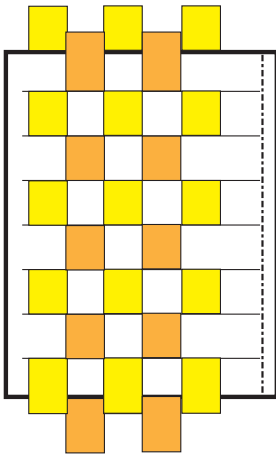

Think About What You Have Learned:

- How do you feel about weaving?
- How could you make your weaving more interesting using natural fibres like cedar bark?
- Do you know anyone who weaves cedar? Do you think they might help you?
- Why do First Nations people think of the cedar as such a special tree?



Activity 14. Cedar Stories

Learning Objectives:

- Interview, summarize, and record stories told by community members
- Describe the importance of stories
- Explore the cultural significance of cedar and its importance in traditional crafts and art

Time:

2+ hours

Materials:

- pencil and paper
- copy for each student of *Student Handout 14: Collecting Cedar Stories*
- recording devices (optional)

Before you start:

Because this is an interview activity, it would be good idea to check out what the cultural sensitivities may be in your community. If you are unsure, contact a cultural liaison person working in your school, the school principal or the band office. This would also be a good time to get a list of community members who could be interviewed or who could come to your class to tell stories about cedar.

Decide how you want to structure this activity. Will students conduct their interviews individually or will you group students into pairs? (Having a partner makes interviewing easier for some students, but can cause scheduling problems.) How would you like students to elaborate and present the stories they have collected? (Straight oral presentations, illustration artwork, etc.)

Process:

1. Hand out copies of *Student Handout 14: Collecting Cedar Stories*.
2. Read together the story *How Cedar Came to Be* and/or the poem *Oh, The Cedar Tree*. Ask: *I wonder if our community has a story about how cedar came to be?* Explain that they are going to have the opportunity to talk to people in their community about cedar.
3. Go through the handout together, explaining how you would like the activity to be structured, timeline for the completed interviews, etc.
4. When interviews are completed, students may present their stories in a variety of ways (you may think of others):
 - Reading the story to a small group or to the rest of the class
 - Illustrating the story as a story strip, or creating a single illustration, before presenting it to the class, either orally with picture-presentation, or by creating a gallery for class viewing

Evaluation:

- Use the *Think About What You Have Learned* questions either in small group or class discussion.
- Students include their story and related artwork in their portfolio.

Extension Suggestion:**Make a Personal Totem Pole**

Remind your students of the importance of cedar as a carving material. Share images of West Coast carvings and totem poles with your students. Some sources are:

- Museum of Northern BC: www.museumofnorthernbc.com
- UBC Museum of Anthropology: www.moa.ubc.ca
- Royal BC Museum ethnology collection: www.royalbcmuseum.bc.ca/Human_History/Ethnolgy.aspx

Discuss the symbols, the inclusion of animals that represent qualities important to First Nations communities. Ask: *If you were going to carve a totem pole to express qualities important to you, what would it look like?* Encourage students to use a variety of media (sketching, paints, paper sculpture, etc.) to create their own totem poles, and to create a key describing the significance of each of the symbols used.

STUDENT HANDOUT 14

Collecting Cedar Stories

How Cedar Came to Be

There are several stories of how cedar came to be. Here is a Coast Salish story, told by Bertha Peters (a Stó:lo Elder), reproduced in *Cedar: Tree of Life to the Northwest Coast Indians* (Stewart, 2005).

There was a real good man who was always helping others. Whenever they needed, he gave; when they wanted, he gave them food and clothing. When the Great Spirit saw this, he said “That man has done his work; when he dies and where he is buried, a cedar tree will grow and be useful to the people – the roots for baskets, the bark for clothing, the wood for shelter”.

Here is a cedar story that is told in the form of a poem, written by the famous Haida carver, Bill Reid.

Oh, The Cedar Tree

*If mankind in his infancy
had prayed for the perfect substance
for all material and aesthetic needs,
an indulgent god
could have provided nothing better.
Beautiful in itself,
with a magnificent flared base
tapering suddenly to a tall, straight trunk
wrapped in reddish brown bark,
like a great coat of gentle fur,
gracefully sweeping boughs,
soft feathery fronds of grey-green needles.*

*Huge, some of these cedars,
five hundred years of slow growth,
towering from their massive bases.
The wood is soft,
but of a wonderful firmness
and, in a good tree,
so straight-grained
it will split true and clean
into forty-foot planks,
four inches thick and three feet wide,
with scarcely a knot.*

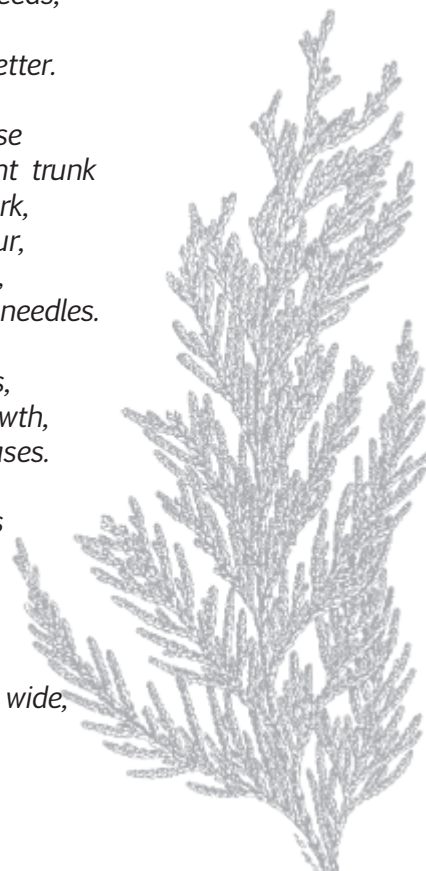

STUDENT HANDOUT 14



*Across the grain
it cuts clean and precise.
It is light in weight
and beautiful in color,
reddish brown when new,
silvery grey when old.
It is permeated with natural oils
that make it one of the longest lasting
of all woods,
even in the damp
of the Northwest Coast climate.*

*When steamed,
it will bend without breaking.
It will make houses and boats
and boxes and cooking pots.
Its bark will make mats,
even clothing.*

*With a few bits of sharpened stone and antler,
some beaver teeth and a lot of time,
with later on a bit of iron,
you can build from the cedar tree
the exterior trappings
of one of the world's great cultures.*

*Above all, you can build totem poles,
and the people of the Northwest Coast
built them in profusion:
forests of sculptured columns
between their houses and the sea,
proudly announcing to all
the heraldic past of those who dwelt there.*

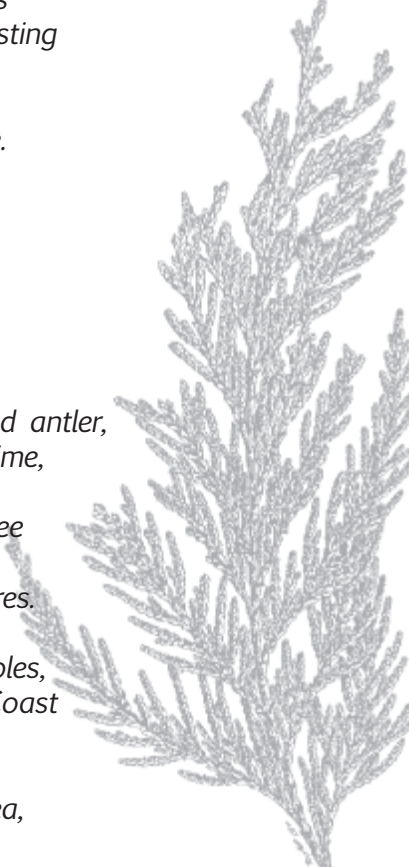

*Bill Reid: Out of the Silence, with Adelaide de Menil, photographer.
1971, New York, Outerbridge & Dienstfrey, p.54-63. Used with
permission, courtesy of the Bill Reid Estate.*

Question to think about: What do the story and the poem tell us about cedar?

STUDENT HANDOUT 14

How to Collect a Cedar Story

In this activity, you will have the chance to talk to someone in your family or your community about cedar stories. You will learn old stories about cedar in your community, and also new stories about cedar.

Plan Your Interview:

Take some time to think about a person you know who likes to tell stories or who you think might want to talk about cedar. When you have decided, tell your teacher. (If you can't think of a person, your teacher may have some good ideas.) Then you will need to talk to your person to set up a time to talk.

Name of person: _____

Time of interview: _____

Things to take:

- this student handout
- a notebook or pieces of paper, and a pen or pencil
- You may also decide to take a digital or tape recorder if you have one. However, some people don't like to be recorded. You need to ask permission in advance if you plan to record your interview with them.

Questions to Ask:

You want to hear a story (or maybe more than one story) about cedar. Let your person know that you would like to share this story with the other students in your class, so you are hoping that the story is one that can be shared. (Some stories are meant to be shared only within families or only with certain people.)

Here are some questions to get you started. You will probably think of more questions as you go.

- Do you know any old stories that our people tell about cedar?
- Do you have any new stories about cedar? (Things that happened to you or other people in the community as they were gathering or using cedar?)
- Can you tell me what things are important to know about gathering, or carving, or weaving cedar?

STUDENT HANDOUT 14

Important Notes on Interviewing:

- If the person is talking faster than you can record what they're saying, just take quick notes to remind you of what they said.
- If you don't understand something, don't be afraid to tell your person you don't quite understand, and ask them to explain a bit more.
- When you have finished your interview, make sure you thank your person.
- As soon as you can, write down your interview. Otherwise, you may forget what some of your notes mean.

Think About What You Have Learned:

- What was the hardest thing about interviewing?
- What did you like about interviewing?
- What did you like best about the story (or stories) that you learned about cedar?
- Do you think that cedar has a special spiritual importance to your community? If so, why?





Activity 15. Wild Products Fair

(Conclusion Activity)

Learning Objectives:

- Summarize and explain to others what they have learned about wild products, using a variety of media
- Plan and organize a school event

Time:

Multiple planning periods spread over 4 weeks leading up to the event (which may take anything from 2 hours to a day)

Materials:

- collected and made creations, foods, and other wild products
- tables
- kitchen supplies
- copies of *Student Handout 15: Wild Products Fair Planner*

Before you start:

During the unit on wild products, encourage your students to compile a portfolio of work, parts of which may be used for the Wild Products Fair. Make sure the group activity products (murals, wall-maps, etc.) are preserved for this event.

Invite community members with expertise in wild products to help your students prepare, and/or to have their own tables at the fair.

Process:

A month ahead:

1. Involve students in a discussion of putting on a Wild Products Fair. *What things could they do? Whom might they invite? What kind of communication and advertising would be needed to make it successful?*
2. Invite those interested to work with you on a Logistics Committee, planning the publicity, coordinating, set-up and clean-up of the event.
3. On the board, write the following headings: **Crafts and Art, Wild Edibles, Medicines, Floral Greenery.** Brainstorm, for each of these topics, ideas of ways to make each topic interesting. Below are some (but not all!) of the ideas your students may come up with.

Wild Edibles

- Collect and harvest in-season foods (berries, roots, leaves)
- Display and share foods that have been collected in other seasons
- Have students present their knowledge through short talks and posters
- Make baked goods with wild edibles (i.e., berry muffins) or show the creation of speciality foods through examples (creating teas)

Medicinal Uses

- Show and talk about appropriate examples of medicinal plants (posters with pictures and collections of plants)
- Exhibit plants where appropriate
- Have a drawing table, where people can draw various medicinal plants

Floral Greenery

- Exhibit examples of floral greenery (create a place where people can exhibit their floral greens in bouquets)
- Teach how to make an interesting floral arrangement using wild products
- Demonstrate how to collect salal and other plants sustainably (have students lead a walk to a nearby

salal patch and show how to sustainably collect salal)

- Have a competition where different floral displays are judged by one or more members of the community

Crafts and Art

- Provide a market setting for students and community members to exhibit their crafts and art (drawings, masks, weavings etc.)
 - Demonstrate how to create different crafts using wild products by having experts and students teach the audience (have some carvers or weavers at the fair)
4. Invite students to sign up for one of the topic groups, and to develop some of the brainstormed suggestions.
 5. Give your students a timetable with blocks of class time to plan their presentations. Encourage them to use *Student Handout 15: Wild Products Fair Planner*.

Leading up to the Event:

6. Meet regularly with your Logistics Committee, and have this group report back to the whole class with their requirements. (Note: Publicity such as creation of posters, writing of school announcements, etc., provides a myriad of learning opportunities in art, language arts, and drama.) If practical, you may want to invite community members to mentor each of the groups.
7. Work with your principal to plan a timetable for different classes to visit the fair, and a way of cycling through the displays so that everyone isn't crowded into the same place. Also, plan to make sure all of your students can experience all of the booths, perhaps the day before or morning of the fair.

Fair Day and After:

8. Help your students to regard the Fair as a creative celebration – make sure everyone has fun.
9. After your bang-up event, make sure you take the time for a class debriefing session. You may decide to structure this as discussion within the small working groups, with reports to the whole class, as a whole-class discussion, or as a writing activity. Some questions are included below in *Think About What You Have Learned*.

Evaluation:

Use the *Think About What You Have Learned* questions in a variety of ways:

- As the basis for small-group discussion, followed by a report-back to the whole class
- For individual reflection, with written answers
- For individual reflection, followed by class discussion

Extension Suggestion:

Does your school or community have a newsletter for parents or a weekly newspaper? This is a good opportunity to engage your students in writing up a report of the highlights of the fair, accompanied by photos.

STUDENT HANDOUT 15

Wild Products Fair Planner

Use this sheet to help you plan your Wild Products Fair Booth

1. What things do you plan to do at your booth? Make a list.

- _____
- _____
- _____
- _____

2. For each activity that you list, write down the following information:

- Activity (what are you calling the thing you plan to do?):
- Description (what will actually happen?):
- Materials (what things do you need to have ready?):
- Time (how much time will it take?):
- Leader (who is going to be the person or people in charge of this activity?):

Note: If your group is planning several activities, you may need more than one sheet of paper. You may also want to make a schedule of what is going to happen when.

Think About What You Have Learned:

After the fair is finished, take some time to think about what you learned.

- What was the most successful activity you did in your booth?
- What would you do differently next time?
- Is there something about wild forest products that you would like to learn more about?
- When you think about the planning and organizing work you did, what were 3 important things you learned?



Glossary

Bough – a branch harvested from a tree often used for decoration in floral greenery (usually between 60 and 90 cm in length).

Business plan – a set of actions, principles, and visions that guides the formation and running of a business.

Canopy – the uppermost levels of a forest, formed by the tree crowns.

Coniferous – the type of tree that has cones and does not shed its needles but stays green all year round.

Conservation – making wise use of resources so that people and the environment will be able to use the same resources in the future.

Cultural sensitivity (or cultural appropriateness) – the ability to detect, appreciate, and be respectful of other ways of knowing and living.

Deciduous – the type of tree or shrub that sheds its leaves or needles seasonally.

Economy – the wealth and resources of a country or region in relation to the production and consumption of goods and services.

Ecosystem – a community of living things interacting with one another and with their nonliving physical environment (soil, sun, wind, weather, etc.).

Evergreen – the type of tree or shrub that doesn't shed its leaves or needles, but maintains them year-round.

First Nations – refers to Aboriginal people. The name implies that they were the “first” people to live in what we now call Canada.

Food web – shows the complex interactions of several species that eat or get eaten by one another. For example, a green plant may get eaten by an ant and a caterpillar, both of whom may get eaten by a small bird, which may be preyed upon by an owl and a fox, who also eats other things.

Fungi - organisms that feed on decomposing plants and animals and help recycle nutrients to the soil, its fruiting body is a mushroom.

Habitat - an animal or plant's “home” in the environment, which provides all its essentials for life, including food, water, shelter, and space throughout the year and throughout the animal or plant's life.

Harvesting – the act of gathering something, like plants or mushrooms

Interconnectedness – the concept that many elements, organisms, and events connect together through systems.

Mushrooms – fruiting bodies that produce spores growing from hyphae of fungi concealed in soil or wood.

Natural resources – the lands, forests, energy sources and minerals existing naturally in a place that can be used by people. Some examples are trees (renewable resource) and oil (non-renewable resource).

Non-timber forest products (NTFPs) – forest plants and fungi (other than timber, pulpwood, shakes, or other wood products) that have value as food, medicine, crafts and art, or floral greenery. Sometimes these are called wild products.

Organism – an individual animal, plant, or single-celled life form.

Over-harvesting – gathering too much of a plant or plants within an ecosystem, so that it may not be able to grow back, and the ecosystem may not be able to recover.

Overpopulation – an increase in the numbers of a species so that the habitat is no longer able to support it.

Resource – something of use to humans, either directly or indirectly.

Sense of place – the relationship that a person or culture has about a certain geographic area, based on knowledge and personal connection.

Small-scale business – a limited sized business, usually only working within one community.

Species – a group of living organisms consisting of similar individuals capable of interbreeding and producing fertile offspring (plants, animals, fungi).

Sustainable - capable of being sustained, of continuing in the future with minimal impact on the environment.

Sustainable Harvesting – collecting species in a way that does not disrupt the balance in an ecosystem, leaving enough of the plant or the ecosystem so that it can re-grow what has been gathered .

Traditional knowledge – indigenous and aboriginal knowledge that is part of tradition and may continue to be practiced.

Values – the principles and standards of behaviour, judgement and what is important in life.

Wild products –species from the forest, excluding lumber or pulpwood, that humans use for commercial, recreational, cultural, spiritual, and subsistence uses. Sometimes called Non-Timber Forest Products (NTFPs).

References

The following references were used in writing this guidebook:

- Berkes, F. (1999). *Sacred Ecology: Traditional Ecological Knowledge and Resource Management*. Ann Arbor (MI): Taylor and Francis
- Canadian Forest Service (2007). *Developing non-timber forest products in Canada*. Canadian Forest Service, Frontline Express, Bulletin No 28. Retrieved October 2, 2008 from <http://cfs.nrcan.gc.ca/news/296>.
- Centre for Non-timber Forest Products (2007). Website home. Retrieved November 28, 2008 from <http://cntr.royalroads.ca/home>.
- Forest Practices Board (2004). *Integrating Non-Timber Forest Products into Forest Planning and Practices in British Columbia*. Retrieved October 3, 2008 from www.fpb.gov.bc.ca/SPECIAL/reports/SR19/SR19.pdf.
- Forrex (2008). *Mushrooms: Non-timber forest products of British Columbia*. Retrieved October 6, 2008 from <http://bcmushrooms.forrex.org/ntfp/pages/sustainableharvest.html>.
- Klinkenberg, Brian. (Editor) 2008. *E-Flora BC: Electronic Atlas of the Plants of British Columbia* [www.eflora.bc.ca]. Lab for Advanced Spatial Analysis, Department of Geography, University of British Columbia, Vancouver.
- Lantz, T.C., Swerhun, K., Turner, N.J. (2004). *Devil's Club (Oplopanax horridus): An ethnobotanical review*. The Journal of the American Botanical Council. 62 (33-48).
- Moore, M. (1993). *Medicinal Plants of the Pacific West*. Red Crane Books, Santa Fe NM.
- Pojar J. & MacKinnon A. (1994). *Plants of Coastal British Columbia including Washington, Oregon, and Alaska*. Lone Pine Publishing, Vancouver BC.
- Pierotti, R. & Wildcat, D. (2000). *Traditional ecological knowledge: The third alternative*. Ecological Applications 10: 1333-1340.
- Reid, B & De Menil, A. (1971). *Out of the Silence*. Outerbridge & Dienstfrey, New York.
- South Moresby Forest Replacement Account. (2000). *Seeing the Forest beneath the Trees: The Social and Economic Potential of Non-Timber Forest Products and Services In the Queen Charlotte Islands/Haida Gwaii*. Joint Initiative of Government of Canada and British Columbia. Retrieved on October 3, 2008 from <http://cntr.royalroads.ca/files-cntr/Seeing%20the%20Forest%20Beneath%20the%20Trees.pdf>.

- Stewart, H. (1984). *Cedar, tree of life to the Northwest Coast Indians*. Douglas & McIntyre, Vancouver BC.
- Turner, N.J., Kuhnlein, H.V., & Egger, K.N. (1986). *The cottonwood mushroom (Thricomala populinum): a food resource for the Interior Salish Indian peoples of British Columbia*. Canadian Journal of Botany. 65 921-927.
- Turner, N.J. (2001). "Doing it right": *Issues and practices of sustainable harvesting of non-timber forest products relating to First Peoples in British Columbia*. BC Journal of Ecosystems and Management. 1(1), pp. 1-11.
- Turner, N.J. (1998). *Plant Technology of First Peoples in British Columbia: Including Neighbouring Groups in Washington, Alberta, and Alaska*. UBC Press, Vancouver BC.
- Turner, N.J. (1995). *Food Plants and Coastal First Peoples*. UBC Press, Vancouver BC.
- Wills, R.M., Lipsey, R.G. (1999). *An economic strategy to develop Non-Timber Forest Products and Services in British Columbia*. Forest Renewal BC Project No. PA97538-ORE. Final Report.

Resources

Want to learn more? These books and websites are excellent sources of factual information and teaching ideas.

Books

Non-timber Forest Products Curriculum Workbook an interdisciplinary set of instructional materials that includes over 100 lesson plans and handouts covering the ecological, cultural, political and economic importance of NTFPs. Order from: www.ifcae.org/projects/ncssf2.

Medicinal Plants of the Pacific West by M. Moore (1993). Red Crane Books, Santa Fe NM.

Plants of Coastal British Columbia including Washington, Oregon, and Alaska by J. Pojar and Andy MacKinnon (1994). Lone Pine Publishing, Vancouver BC.

Cedar, tree of life to the Northwest Coast Indians by H. Stewart. (1984). Douglas & McIntyre, Vancouver BC.

Plant Technology of First Peoples in British Columbia: Including Neighbouring Groups in Washington, Alberta, and Alaska by Nancy J. Turner (1998). UBC Press, Vancouver BC.

Food Plants and Coastal First Peoples by Nancy J. Turner (1995). UBC Press, Vancouver BC.

Websites

Royal Roads University's Centre for Non-timber Resources

The Centre for Non-Timber Resources at Royal Roads University is an applied research and development centre dedicated to promoting the sustainable use of non-timber forest resources.

<http://cntr.royalroads.ca>

Sierra Club Environmental Education

Started in 1998 in response to teacher requests for environmental education materials, the Sierra Club Education Program has grown into one of B.C.'s most effective environmental education providers. Please contact Sierra Club directly if you are interested learning more.

www.sierraclub.bc.ca/education

Coastal First Nations Great Bear Initiative

Coastal First Nations is an alliance of First Nations on British Columbia's North and Central Coastal and Haida Gwaii. Coastal First Nations includes the Wuikinuxv Nation, Heiltsuk Nation, Kitasoo/Xaixais First Nation, Gitga'at First Nation, Haisla Nation, Metlakatla First Nation, Homalco First Nation, Old Massett Village Council, Skidegate Band Council, and the Council of the Haida Nation who have been working together on socio-economic issues since 2000, and formed the Turning Point Initiative Society in 2003.

www.coastalfirstnations.ca

First Voices

FirstVoices is a suite of web-based tools and services designed to support Aboriginal people engaged in language archiving, language teaching & culture revitalization.

www.firstvoices.com

Greenlearning - Pembina Institute

GreenLearning designs premier learning resources for Canada's innovative teachers. Our lessons and activities are comprehensive, fun and free. Most resources are curriculum-aligned to British Columbia, Alberta and Ontario — with links to other provinces coming soon.

www.greenlearning.ca

Robert Bateman Get to Know Program

Built on research and supported by a diverse array of educators, organizations, governments, and corporations, the Robert Bateman Get to Know Program has been inspiring connections between youth and nature for nearly a decade. Focused on encouraging youth to go outdoors and “get to know” their wild neighbours, the program's initiatives include the writing and art contest, the interactive CD, products, and the school program.

<http://gettoknow.ca>

E-Flora BC

An electronic atlas of the plants of British Columbia based out of the University of British Columbia.

www.eflora.bc.ca

Royal BC Museum Plant Information

A list of BC plants with information on each one.

www.royalbcmuseum.bc.ca/Natural_History/Plants.aspx?id=274



Appendix A:

Specific Prescribed Learning Outcomes

Grade 4	
<p>Social Studies</p> <p>Aboriginal Cultures, Exploration, and Contact</p> <ul style="list-style-type: none"> apply critical thinking skills identify patterns and summarize identify alternative perspectives describe technologies used by Aboriginal people identify the significance of selected place names describe Aboriginal peoples' relationship with the land and natural resources 	<ul style="list-style-type: none"> Activity 1 - Get to Know a Plant Activity 2 - Learn about Leaf Patterns Activity 3 - Make a Plant Map Activity 4 - Thanks for Plants Activity 5 - How to Sustain Ecosystems Activity 6 - The Forest Food Web Game Activity 7 - Making a Seasonal Harvest Calendar Activity 8 - Gathering Berries for Jam Activity 9 - The Business of Mushrooms Activity 13 - Cedar Weaving Activity 14 - Cedar Stories Activity 10 - Learning about Devil's Club Activity 11 - Making Tea Activity 12 - Making Wreaths Activity 15 - Wild Products Fair

Specific Prescribed Learning Outcomes

Grade 4	
<p>Science</p> <p>Processes and Skills of Science</p> <ul style="list-style-type: none"> make predictions recognize patterns and relationships and reach conclusions <p>Life Science: Habitats and Communities</p> <ul style="list-style-type: none"> compare structures and behaviours of local animals and plants compare different habitats and communities analyse food chains understand the Aboriginal concept of respect for the environment recognize how personal action has environmental consequences 	<ul style="list-style-type: none"> Activity 1 - Get to Know a Plant Activity 2 - Learn about Leaf Patterns Activity 3 - Make a Plant Map Activity 4 - Thanks for Plants Activity 5 - How to Sustain Ecosystems Activity 6 - The Forest Food Web Game Activity 7 - Making a Seasonal Harvest Calendar Activity 9 - The Business of Mushrooms Activity 10 - Learning about Devil's Club Activity 12 - Making Wreaths Activity 13 - Cedar Weaving Activity 14 - Cedar Stories Activity 15 - Wild Products Fair
<p>Mathematics</p> <p>Number Concepts</p> <ul style="list-style-type: none"> demonstrate a number sense for whole numbers apply arithmetic operations on use in problem solving <p>Patterns and Relations</p> <ul style="list-style-type: none"> investigate, establish, and communicate predictions based on patterns <p>Shape and Space</p> <ul style="list-style-type: none"> estimate, measure, and compare quantities describe relationships 	<ul style="list-style-type: none"> Activity 1 - Get to Know a Plant Activity 2 - Learn about Leaf Patterns Activity 3 - Make a Plant Map Activity 6 - The Forest Food Web Game

Specific Prescribed Learning Outcomes

Grade 5	
<p>Social Studies</p> <p>Canada – from Colony to Country</p> <p>critical thinking skills (e.g., hypothesizing, comparing, identifying patterns)</p> <p>maps and timelines of features of BC and Canada</p> <p>gathering information</p> <p>defending a position</p> <p>plan of action to address a school, community, or national issue</p> <p>understanding of First Nations governance</p>	<p>Activity 1 - Get to Know a Plant</p> <p>Activity 3 - Make a Plant Map</p> <p>Activity 4 - Thanks for Plants</p> <p>Activity 5 - How to Sustain Ecosystems</p> <p>Activity 6 - The Forest Food Web Game</p> <p>Activity 9 - The Business of Mushrooms</p> <p>Activity 10 - Learning about Devil's Club</p> <p>Activity 13 - Cedar Weaving</p> <p>Activity 14 - Cedar Stories</p> <p>Activity 15 - Wild Products Fair</p>
<p>Science</p> <p>Earth and Space Science: Renewable and Non-Renewable Resources</p> <p>analyse an Aboriginal concept of interconnectedness</p> <p>describe environmental impacts</p>	<p>Activity 1 - Get to Know a Plant</p> <p>Activity 3 - Make a Plant Map</p> <p>Activity 4 - Thanks for Plants</p> <p>Activity 5 - How to Sustain Ecosystems</p> <p>Activity 6 - The Forest Food Web Game</p> <p>Activity 10 - Learning about Devil's Club</p> <p>Activity 12 - Making Wreaths</p> <p>Activity 13 - Cedar Weaving</p> <p>Activity 14 - Cedar Stories</p> <p>Activity 15 - Wild Products Fair</p>

Specific Prescribed Learning Outcomes

Grade 5	
<p>Mathematics</p> <p>Numbers and Number Concepts demonstrate a number sense for whole numbers, from 0 to 100 000 apply arithmetic operations on whole numbers and decimal fractions</p> <p>Patterns and Relations construct, extend, and summarize patterns</p> <p>Shape and Space (Measurement) use measurement concepts and appropriate tools to solve problems</p>	<p>Activity 1 - Get to Know a Plant</p> <p>Activity 2 - Learn about Leaf Patterns</p> <p>Activity 3 - Make a Plant Map</p> <p>Activity 5 - How to Sustain Ecosystems</p> <p>Activity 6 - The Forest Food Web Game</p>
Grade 6	
<p>Social Studies</p> <p>Canada and the World critical thinking skills understanding relationships, summarizing, and drawing conclusions formal presentation skills plan of action to address a problem or issue relationship between cultures and their environments artistic expression and culture</p>	<p>Activity 1 - Get to Know a Plant</p> <p>Activity 4 - Thanks for Plants</p> <p>Activity 5 - How to Sustain Ecosystems</p> <p>Activity 6 - The Forest Food Web Game</p> <p>Activity 8 - Gathering Berries for Jam</p> <p>Activity 9 - The Business of Mushrooms</p> <p>Activity 10 - Learning about Devil's Club</p> <p>Activity 11 - Making Tea</p> <p>Activity 12 - Making Wreaths</p> <p>Activity 13 - Cedar Weaving</p> <p>Activity 14 - Cedar Stories</p> <p>Activity 15 - Wild Products Fair</p>

Specific Prescribed Learning Outcomes

Grade 6	
<p>Science</p> <p>Life Science: Diversity of Life analyse how different organisms adapt to their environments</p> <p>Earth and Space Science: Exploration of Extreme Environments explain obstacles of extreme environments assess technologies used for extreme environments</p>	<p>Activity 1 - Get to Know a Plant</p> <p>Activity 3 - Make a Plant Map</p> <p>Activity 2 - Learn about Leaf Patterns</p> <p>Activity 5 - How to Sustain Ecosystems</p> <p>Activity 6 - The Forest Food Web Game</p> <p>Activity 13 - Cedar Weaving</p> <p>Activity 14 - Cedar Stories</p>
<p>Mathematics</p> <p>Numbers and Number Concepts develop a number sense for whole numbers apply arithmetic operations in solving problems</p> <p>Patterns and Relations use relationships to summarize, generalize, and extend patterns</p> <p>Shape and Space solve problems involving shape measurements create patterns that incorporate symmetry, translations, and reflections</p>	<p>Activity 1 - Get to Know a Plant</p> <p>Activity 2 - Learn about Leaf Patterns</p> <p>Activity 3 - Make a Plant Map</p> <p>Activity 5 - How to Sustain Ecosystems</p> <p>Activity 6 - The Forest Food Web Game</p>
<p>Physical Education</p> <p>Knowledge relate personal physical and emotional health to physical activity</p>	<p>Activity 4 - Thanks for Plants</p> <p>Activity 10 - Learning about Devil's Club</p>

Specific Prescribed Learning Outcomes

Grade 7	
<p>Social Studies</p> <p>Ancient Civilizations</p> <ul style="list-style-type: none"> critical thinking skills identifying relationships, summarizing, and drawing conclusions compiling information from a range of sources defending a position on an issues influences of ancient societies on present-day cultures 	<ul style="list-style-type: none"> Activity 1 - Get to Know a Plant Activity 4 - Thanks for Plants Activity 5 - How to Sustain Ecosystems Activity 6 - The Forest Food Web Game Activity 10 - Learning about Devil's Club Activity 13 - Cedar Weaving Activity 14 - Cedar Stories Activity 15 - Wild Products Fair
<p>Science</p> <p>Life Science: Ecosystems</p> <ul style="list-style-type: none"> analyse the roles of organisms as part of interconnected food webs, populations, communities, and ecosystems assess interactions between organisms and the environment assess the requirements for sustaining healthy local ecosystems evaluate human impacts on local ecosystems 	<ul style="list-style-type: none"> Activity 1 - Get to Know a Plant Activity 3 - Make a Plant Map Activity 4 - Thanks for Plants Activity 5 - How to Sustain Ecosystems Activity 6 - The Forest Food Web Game Activity 9 - The Business of Mushrooms Activity 10 - Learning about Devil's Club Activity 13 - Cedar Weaving Activity 14 - Cedar Stories Activity 15 - Wild Products Fair

Specific Prescribed Learning Outcomes

Grade 7	
<p>Mathematics</p> <p>Numbers and Number Concepts demonstrate a number sense apply arithmetic operations in solving problems</p> <p>Patterns and Relations express patterns in terms of variables and make predictions</p> <p>Shape and Space create and analyse patterns and designs</p>	<p>Activity 1 - Get to Know a Plant</p> <p>Activity 2 - Learn about Leaf Patterns</p> <p>Activity 6 - The Forest Food Web Game</p>
<p>Physical Education</p> <p>Knowledge relate the regular participation in physical activities to quality of life analyse the relationship between nutrition and physical activity</p>	<p>Activity 4 - Thanks for Plants</p> <p>Activity 10 - Learning about Devil's Club</p>

Arts Prescribed Learning Outcomes

Other PLOs that relate to this guidebook can be found in subject areas such as:

English Language Arts PLOs through:

- oral Language
- reading and viewing
- writing and representing

Visual Arts PLOs through:

Image-Development and Design Strategies:

- identifying and comparing image-development and design strategies
- drafting ideas for images using feelings, observation, memory, and imagination
- using a variety of design strategies, including reproduction
- using a variety of media
- communicating ideas, experiences, and stories

Context:

- identifying art from various cultures
- giving reasons for preferences in artworks
- demonstrating an awareness of various types of artists
- demonstrating respect for the work of self and others
- creating images that express personal identity

Materials, Technologies, and Processes:

- classifying images
- identifying characteristics of materials, tools, equipment, and processes
- suggesting reasons for following safe and environmentally sensitive procedures

Health and career education through:

- being physically active
- participating in outdoor learning
- learning about healthy diet options
- demonstrating understanding of traditional foods
- recognizing personal career options

Appendix B:



Field Trip Checklist

Note: For more pointers and other resources, visit the For Educators page of Sierra Club's Education website: www.sierraclub.bc.ca/education.

How to Plan

1. What is your reason for going? What will you be seeing and doing?
2. Select the site that you wish to visit. Some sites you may need to visit prior to going outdoors to become familiar with trails and also the possible safety hazards.
3. Check for permission. Permission letters from parents may be needed; as well, permission from the resource people you may be visiting might be required. Take this opportunity to let parents know of any things that students should remember to bring that day.
4. Estimate trip costs. This may include bus costs, lunch or spending money.
5. Select and contact any resource people. A good ratio is one leader to five students. People to include are parents, community members, university students and individuals from local organizations or who work for the band office. It's amazing who will come and talk - if you ask them!
6. Think of a back-up plan. This includes rain plans and alternatives in case of trip cancellation, as well as an emergency medical plan.
7. Prepare the students with some information on what they will see. It helps to have pointers on what to look for.

What to Bring

Students:

- Appropriate clothing, including raingear
- Proper footwear that is waterproof and has a good tread
- Insect repellent and/or sun protection lotion
- Field notebooks with attached pencil
- Snacks and/or a lunch and a full water bottle

Teacher: you may want to also bring:

- First aid kit and someone who knows first aid
- Whistle
- Binoculars and /or magnifying glasses
- Pocket knife
- Local field guides to look up animals, plants, trees, etc.
- Garbage bags - they make great rain gear or seats for wet days
- Pencils
- Toilet paper
- A good story to read aloud during lunch time.

Safety Rules

It is important to discuss with students before going outdoors the importance of appropriate outdoor behaviour and set ground rules.

- Set up a meeting signal to get everyone together once you are outside, such as raising your hand or using a whistle.
- Set boundaries and explain the importance of staying within them.
- Follow all directions (make sure your directions are clear and that the students understand them).
- Never taste or eat a wild plant unless you are accompanied by an adult who knows for certain it is safe.
- Stay with a buddy, to keep from getting lost or separated.

Conservation Rules

In addition to the basic rules, it is important to remember that because we are guests visiting the outdoors there are certain special rules we must follow:

- All living things, including plants, are to be respected and not injured in any way. The basic rule: look, learn and leave alone.
- If it is necessary to handle an organism, be very gentle. Be aware that some animals might bite to protect themselves.
- Return all organisms to the spot they were found as soon as the observation is complete. This includes replacing their surrounding habitat as you found it. For example, if you found a slug under a leaf, put the slug back under that same leaf.
- Stay on the trail. If you stray off, you may accidentally destroy someone's habitat.
- Pack out what you pack in. Don't leave garbage behind.

STUDENT HANDOUT

Appendix C:

Working in a Small Group

Working in a small group is a great way to learn, discuss, and work together. To work well and efficiently, you have to be able to organize yourselves. Here are some suggestions.

Group Roles

Your group can work more smoothly if you have different people in charge of different things. It's a good idea to have different people take turns in these roles, so that you all get experience. Depending on the task, you may not need all of these roles. You will usually need a facilitator, though, just to keep everyone focused on the group task.

Here are the most usual group roles:

- **Facilitator** – makes sure that everyone gets to speak, that the group follows the instructions, stays on topic, and gets the task done. The facilitator is a bit like a teacher. If someone in the group wants to fool around and waste time, it's up to the facilitator to ask that person to come back to the task, and it's up to all the other group members to support the facilitator.
- **Recorder** – writes down the group's main ideas. Sometimes this is done in a notebook. Other times your teacher will ask you to print things on chart paper so that the rest of the class can read it.
- **Timekeeper** – keeps track of how the time is going, and tells the group if they need to move on to the next part of the task in order to get finished in time.
- **Reader** – reads an article or section of information aloud to the rest of the group.
- **Reporter** – reports back to the rest of the class. (Sometimes, the reporter is also the recorder, but your group may decide to have 2 different people in these roles.)

Tips for all Group Members:

You are responsible to work with the rest of the group to do a good job. **Here are some pointers:**

- Take your turn – try to contribute, but try not to take up more than your share of time.
- Make sure you listen to what others are saying, and consider their ideas as well as your own.
- Even if you disagree, don't put anyone down. See if you can come to a compromise that works for everyone.
- Keep focused on the task, and work as hard as you can to make sure your group does well.

At first it may not seem easy to work in a group, but as you practice you'll find it's a great way to learn.



